



Contents

- Introduction 1
- Shipping and Receiving.....1
- Handling 1
- Short Term Storage.....2
- Long Term Storage.....2
- Foundations and Supporting Structures.....2
- Fan Installation 2
 - Factory Assembled Units 2
 - Disassembled Units.....2
- Fan Operation – Safety.....4
- Operation Checklist.....4
- Maintenance of Fans.....5
 - General Motor Maintenance.....5
 - Drive Maintenance.....5
 - Bearing Maintenance.....6
 - Lubrication.....6
 - Wheel and Shaft Maintenance.....6
 - Structural Maintenance6
- Troubleshooting Guidelines.....6
- Troubleshooting Performance Problems
 - Air Capacity Problems.....7
 - Noise Problems7
 - Vibration Problems.....7
 - Motor Problems.....7
 - Drive Problems7
 - Bearing Problems.....7
- Limitation of Warranties and Claims8

Introduction

The purpose of this manual is to provide instructions that complement good general practices when installing or operating fans manufactured by Twin City Fan & Blower. It is the responsibility of the purchaser to provide qualified personnel experienced in the installation, operation, and maintenance of air moving equipment.

Instructions given in the body of this manual are general in nature and apply to a variety of models manufactured by Twin City Fan & Blower. Most units can be installed and maintained with the instructions given.

Special applications may require additional information. These instructions are supplied in the form of attached appendices. Use the instructions in the appendix if the directions in this manual differ from instructions in the appendix.

As always, follow good safety practices when installing, maintaining and operating your air moving equipment. A variety of safety devices are available. It is the user's responsibility to determine adequate safety measures and to obtain the required safety equipment.

Shipping and Receiving

All Twin City Fan & Blower products are carefully constructed and inspected before shipment to insure the highest standards of quality and performance.

Compare all components with the bill of lading or packing list to verify that the proper unit was received.

Check each unit for any damage that may have occurred in transit. Any damage should be reported immediately to the carrier and the necessary damage report filed.

Handling

Handling of all air moving equipment should be conducted by trained personnel and be consistent with safe handling practices. Verify the lift capacity and operating condition of handling equipment. Maintain handling equipment to avoid serious personal injury.

Units shipped completely assembled may be lifted with slings and spreader bars. Use well-padded chains, cables or nylon straps. On most units, lifting lugs are provided for attaching chains (see Figure 1). Lift the fan in a fashion that protects the fan and fan coating from damage. Never lift a fan by the inlet or discharge flange, shafting or drives, wheel or impeller, motor or motor base, or in any other manner that may bend or distort parts.

Partial or disassembled units require special handling. All parts should be handled in a fashion which protects the coatings and parts from damage. Components should be handled such that forces are not concentrated and bending or distortion cannot occur.

Figure 1. Lifting Lug Locations

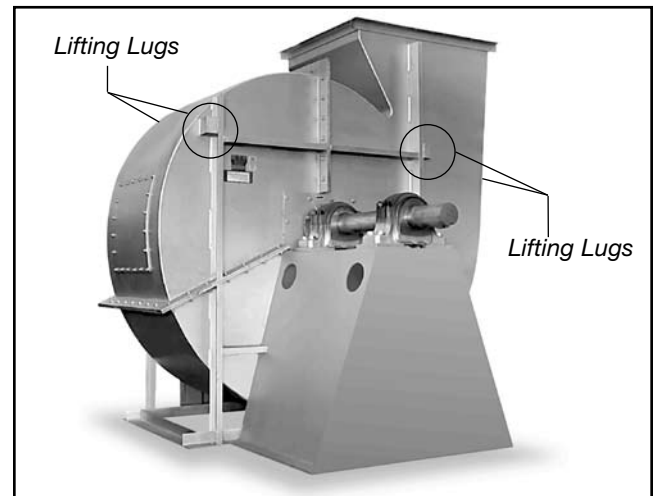

Housing should be lifted using straps and spreaders. Do not distort housing or side plates when lifting.

Bearing pedestals should be lifted using straps or padded chains. Under no circumstances should an attached or separated bearing pedestal be lifted by the shaft, bearings, drives, motor or wheel.

The shaft and wheel assembly may be lifted using a hoist and a spreader with a sling around the shaft at points nearest the wheel (see Figure 2). Take care not to scratch the shaft where the wheel or bearings will be mounted. Never lift or support the assembly by the wheel. Always support the assembly by the shaft when lifting or storing. Do not support the shaft or the wheel on housing

Figure 2. Moving Shaft and Wheel with Spreader Bar

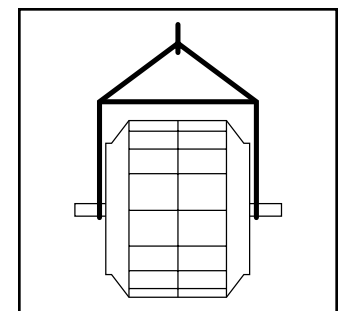

sides. Use only the key provided with the shaft and wheel.

Wheels shipped separately can be lifted by slings running through the blades and around the hub. Never lift the wheel by blades or flanges. Always transport wheels by lifting. Do not roll the wheel as this can damage coatings and change the balance of the wheel.

Bent shafting is a source of vibration and bearing failure, so handle the shaft with care. Any scratches on the shaft may be removed with fine emery cloth or a stone.

Short Term Storage

If fan installation is to be delayed, store the unit in a protected area. Protect the fan and motor bearings from moisture and vibration (or shock loading).

Long Term Storage

Prior to Storage – Fan bearings (and motor bearings per the motor manufacturer's specifications) are to be greased at the time of going into extended storage. On belt drive units the belt tension should be reduced to less than half the specified value for the fan's design to prevent a sag/set from forming in the shafts and belts. If the unit was supplied with a motor, the motor windings should be measured at this time and recorded for comparison prior to placing in service. If the fan housing was supplied with a drain connection, this plug should be removed to prevent any moisture from accumulating in this portion of the unit during storage.

Storage Procedure – Fans should be stored indoors whenever possible where control over temperature, shock and dust is reasonably maintained. If units are to be stored outside in the elements, they should be covered with a water-resistant material. The bearings should be shielded individually from water and dirt; however, do not tightly seal to avoid trapping condensation. Stored equipment should be stored on a clean, dry floor or blocked up off the ground on blocks to prevent unit from setting in any water or directly on the ground. If shock or vibration will be present during storage, the unit may need to be placed on some type of vibration dampening material to aid in preventing brinelling of the bearing surfaces.

Periodic Check – On a monthly interval, the equipment should be checked to ensure that it has remained in an acceptable stored condition. The fan (and motor if supplied) should be rotated several times by hand while adding enough grease to replenish the bearing surfaces with fresh grease and to maintain a full bearing cavity. Grease used must be compatible with that already supplied in the motor and fan bearings. The fan impeller should be left at approximately 180 degrees from that of the previous month to prevent the shaft and impeller from taking a set in one position. Storage records should be maintained which indicate the above requirements have been followed. Consult the motor manufacturer for proper storage, space heater connection and lubrication if the unit was supplied with one.

Start-Up – When the unit is removed from storage, all bearing grease should be purged and replenished with fresh grease as per the lubrication decal. The motor should be measured to verify that the resistance is still at a satisfactory level compared to the value recorded prior to storage.

Foundations and Supporting Structures

Floor mounted fans should be installed on a flat, level, rigid concrete foundation with a mass at least three to five times that of the assembly supported as a guide, depending on the size and speed of the fan. Foundation shall be suitable for static and dynamic loads and foundation frequencies be separated at least 20% from the rotational speed/speed ranges. The plan area should be no more than twice that required by the equipment. Foundations with larger areas should have correspondingly larger mass. Anchor bolts should be "L" or "T" shaped with sufficient length for nuts, washers, shims, and threads for draw-down. Each bolt should be placed in a sleeve or pipe with a diameter larger than the bolt to allow for adjustment.

If the fans are mounted on a sub-structure, an inertia base with spring isolator system should be considered.

Fans mounted to or within a structure should be placed as close as possible to a rigid member such as a wall or column. The structure must be designed for rotating equipment; static design for strength is not sufficient to insure proper operation. Supports for suspended fans must be cross-braced to prevent side sway. Structural resonance should be at least 20% from fan operating speed. Vibration isolators should be used where applicable.

Any ducting should have independent support; do not use the fan to support ducting. Isolating the fan from ductwork with flex connections eliminates transmission of vibration. Fans handling hot gases require expansion joints at both the inlet and discharge to prevent excessive loads caused by thermal growth.

Fan Installation – Factory Assembled Units

Follow proper handling instructions given earlier.

1. Move the fan to the final mounting position.
2. Remove skid, crates, and packing materials carefully.
3. If supplied, place vibration pads or isolation base on mounting bolts. Line up holes in fan base with bolts.
4. Place fan on mounting structure. Carefully level unit using shims as required at all mounting hole locations. Bolt down the unit.
5. Any grout may now be used. Bolt the fan in position before applying grout. Do not depend upon grout to support rotating equipment.
6. Continue with Operations Checklist.

Additional instructions may be given for some fan models, components and accessories in the appendix.

Fan Installation – Disassembled Units

A unit is considered "disassembled" if any component required for proper operation is shipped or supplied separately or in pieces. Reference earlier instructions concerning proper handling of fan components.

Instructions for Mounting and Assembly of Unit:

1. Move lower housing/framework to mounting location.
2. If vibration pads or bases are used, place on bolts first. Place lower housing assembly onto bolts.
3. Level and shim if required. Bolt into place.
4. If separated pedestal or bearing pedestal:
 - a. Bring bearing pedestal to desired location.
 - b. Place any vibration base or pads into place. Set bearing pedestal on bolts.
 - c. Never distort bearing pedestal by forcing it to align with a non-level surface. Shim beneath the pedestal as required.

- d. Check bearing centerline height. Change centerline height to match centerline height of housing. High temperature units may require the housing centerline to be lower when cold so that it will be centered when hot.
 - e. Measure from housing to bearing pedestal to bring bearing pedestal into square with housing (a large square may also suffice).
 - f. Bolt into position.
5. Shaft and wheel assembly preparation:
- a. Clean protective coating off shaft with solvent. Do not touch clean areas of shaft with hands. Perspiration can cause rust or pitting over time.
 - b. Remove keys from shaft.
 - c. Clean inside of wheel bore with solvent. Make sure setscrews will not interfere when inserting shaft into wheel bore.
6. Arrangement 1, 9 or 10: Drive Component Assembly (See Figure 3):
- a. Insert shaft into wheel from back side of wheel.
 - b. When shaft is flush with wheel hub, put key into keyway and tighten wheel setscrews.
 - c. Insert shaft through opening in drive side. (If split housed unit, lower into position.)
 - d. Install bearings onto shaft. Do not tighten bearing setscrews at this time. The bearing housing should be perpendicular and the bearing base parallel to the axis of the shaft to prevent loads caused by misalignment.
 - e. Mount assembly, bolt bearings to drive stand. Shaft must be parallel with side of bearing pedestal. After aligning and bolting bearings to pedestal, tighten bearing setscrews. Continue with step 8.

Figure 3. Drive Component Assembly

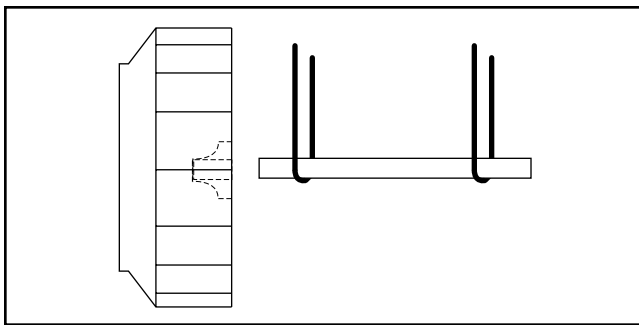

7. Arrangement 3 (Split-housed) units (See Figure 4):
- a. Parts on DWDI units are assembled in the following order as viewed from opposite drive side: Bearing bar assembly and opposite bearing, funnel, (housing side), wheel, (housing side), funnel, drive side bearing bar assembly, drive bearing and sheaves. Mount bearing bar assembly to housing. Center wheel in funnels.
 - b. Parts on SWSI units are assembled in the following order as viewed from opposite drive side: Bearing bar assembly and opposite bearing, funnel, (housing side), wheel, (housing side), drive side bearing bar assembly, drive bearing and sheaves. Mount bearing bar assembly to housing. (See Figure 7 for wheel-funnel overlap.)
 - c. Assemble parts in above order on shaft.
 - d. Move assembly into position. Lightly bolt bearings into place.

Figure 4. Split-housed Drive Component Assembly

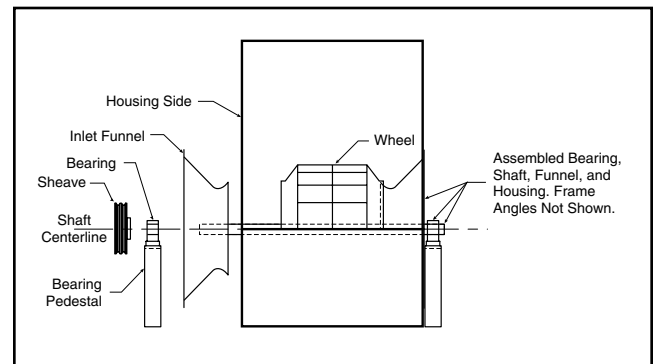

- e. Shaft should be parallel with discharge of housing. Move bearings to accommodate.
 - f. Level shaft; shim bearings if required. Tighten bearing setscrews.
8. Install motor on base. Carefully align shafts for drive installation.
9. Mount drives as follows:
- a. Slip (do not pound) proper sheave onto corresponding shaft. **CAUTION: PLACING FAN SHEAVE ON MOTOR CAN OVERSPEED WHEEL AND CAUSE STRUCTURAL FAILURE.**

Figure 5. Sheave Position

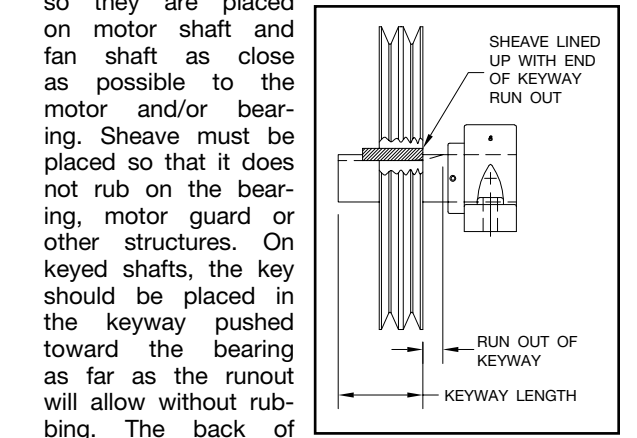

- b. Position sheaves so they are placed on motor shaft and fan shaft as close as possible to the motor and/or bearing. Sheave must be placed so that it does not rub on the bearing, motor guard or other structures. On keyed shafts, the key should be placed in the keyway pushed toward the bearing as far as the runout will allow without rubbing. The back of the sheave should be lined up with the end of the key (see Figure 5). For sheaves without a key, the sheave should be placed as close to motor and/or bearing as possible without rubbing. Typically the sheave should be at least $\frac{1}{4}$ " away from the motor, bearing, guard, structures, etc.

Figure 6. Sheave Alignment

- c. Align sheaves with a straight-edge extended along the perimeters of both sheaves, just making contact in two places on outside perimeters of both sheaves (see Figure 6).
- d. Tighten down sheave bolts.
- e. Install a matched set of belts. Slide the motor to obtain slack and tighten belts. Using a pry will damage belts.
- f. Tighten belts to proper belt tension. Ideal tension is just enough tension so that belts do not slip under peak load. Recheck sheave alignment.

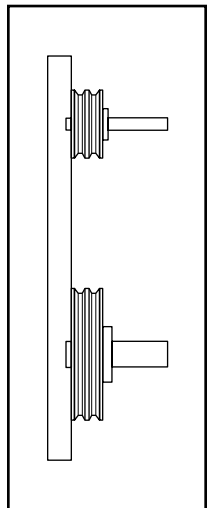
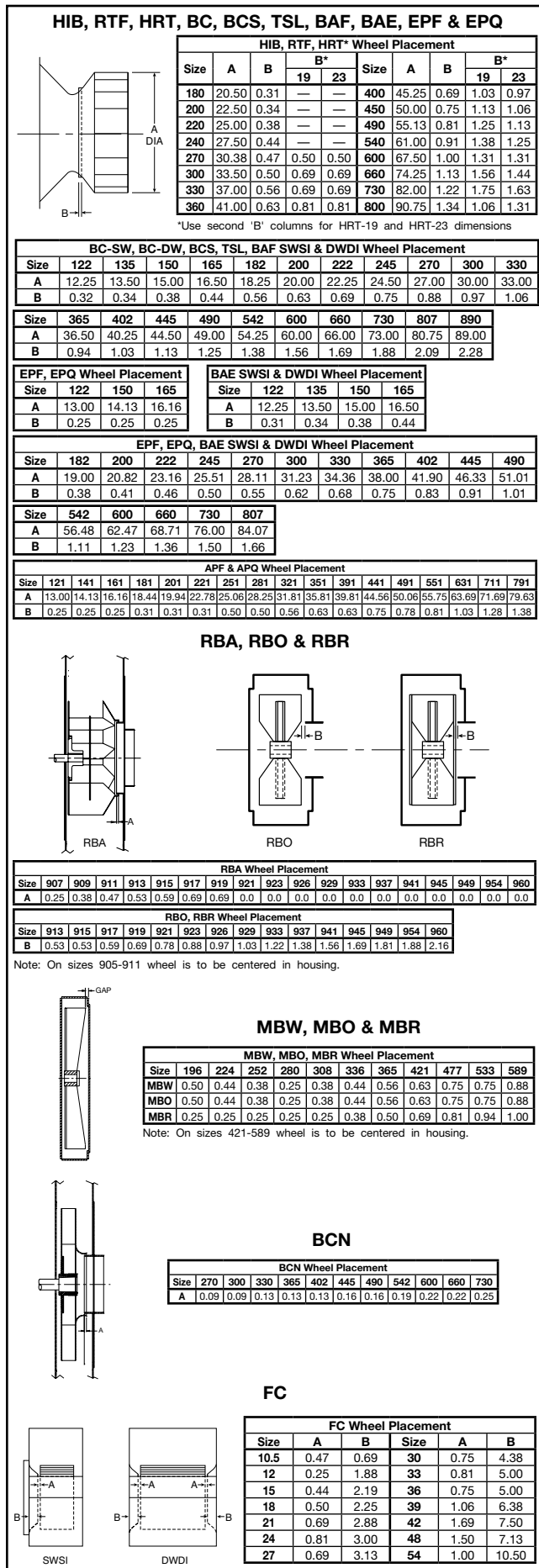

Figure 7. Wheel-Funnel Overlap



- g. After initial installation of belts, recheck belt tension again after a few days to adjust belt tension. (New belts require a break-in period of operation.)
10. Install any safety devices or accessories supplied. (Accessories commonly used are inlet vanes, shaft seals and shaft coolers, plugs, dampers, and inlet or discharge screens. Refer to appropriate documents in appendix.)
11. Grout may now be applied. Grout is used to distribute loads and should not be used as the sole support of any rotating equipment.
12. When connecting the fan to the system, it is recommended that the inlet and discharge be isolated from the system with flex connections (where practical) to block transmitted vibration. All duct connections to the fan should be independently supported. Do not use fan to support duct.

Fan Operation - Safety

For general safety practices for air moving equipment, see AMCA Bulletin 410.

Twin City Fan & Blower has many safety accessories available. These safety devices include (but are not limited to) belt guards, shaft guards, inlet and discharge screens. The use, abuse, or non-use of safety devices is the responsibility of the purchaser.

Facility-related safety conditions include fan accessibility and location. How easily can non-service personnel access the unit? Is the fan in a hazardous duty environment? Was the unit ordered for this duty? Other concerns must also be addressed. All fans should be powered through switches which are easily accessible to service personnel from the fan. Every switch should have the ability to be "locked-off" by the service person and the key to be retained by this person to prevent accidental power of the fan while service is in process.

Operation Check List

Verify that proper safety precautions have been followed:

- Electrical power must be locked off.
- Check fan mechanism components:
 - System connections are properly made and tightened.
 - Bearings are properly lubricated.
 - Wheel, drives and fan surfaces are clean and free of debris.
 - Rotate the impeller by hand to verify it has not shifted in transit.
 - Check fan/wheel overlap. (See Figure 7.)
 - Drives on correct shafts (not reversed).
 - Check position of guards to prevent rubbing.

- Check fan electrical components:
- Motor is wired for proper supply voltage.
 - Motor was properly sized for power and rotational inertia of rotating assembly.
 - Motor is properly grounded.
 - All leads are properly insulated.

- Trial "bump":
- Turn on power just long enough to start assembly rotating.
 - Check rotation for agreement with rotation arrow. Does the assembly make any unusual noise? (See Figure 8.)
 - Check drive alignment and tension. Does this meet with drive manufacturer's recommendations?
 - Correct any problems which may have been found. (Follow safety guidelines - shut power off.) Perform checklist again until unit is operating properly.
 - Run unit up to speed.

Figure 8. Proper Wheel Rotation

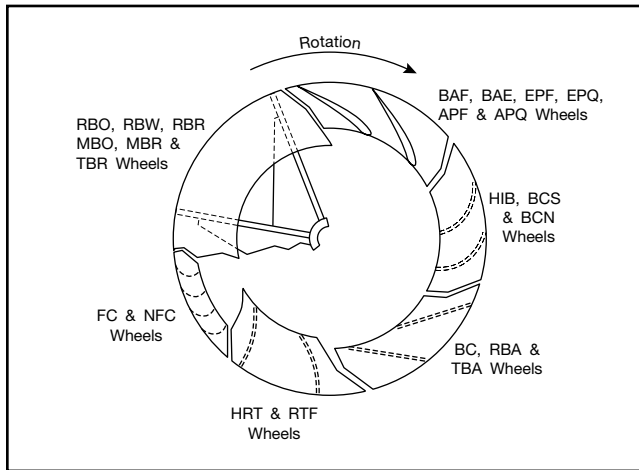

Verify fastener tightness. These may have loosened during shipment or installation.

- Setscrews attaching wheel hub to shaft.
- Setscrews in drive sheaves or coupling.
- Nuts on inlet funnel.
- Nuts and bolts holding motor.
- Nuts holding housing frame to base and base to ground.
- Nuts on accessories including shaft seal, access doors and pie-splits.
- Bolts in taper-lock bushings.
- Grease line connections.

After one week of operation, check all nuts, bolts and setscrews and tighten if necessary.

Maintenance of Fans

This section contains general maintenance instructions for your Twin City Fan & Blower unit. For specific information about maintenance of components, particularly for special application fans, see the attached documents.

General Motor Maintenance

The three basic rules of motor maintenance are keep the motor clean, dry and properly lubricated.

Keeping motors and windings clean is important because dirt and dust serve as thermal insulators. Heat normally dissipated by the motor is trapped causing overheating and/or premature failure. Blow dust and dirt out of windings and off the motor periodically. Use low pressure (50 psig) airstream so that winding damage does not occur. Keep the area surrounding the motor open so the air can circulate through the motor cooling fan. Follow normal maintenance schedule given to the right.

Motors should be kept dry to avoid electrical short circuits. Motors kept in storage for long periods of time can have moisture condense on the windings. Be certain the motor is dry before using.

Some smaller motors are lubricated for life. Motor bearing lubrication, if required, must follow a rigorous schedule. Motors less than 10 hp running about eight hours a day in a clean environment should be lubricated once every five years; motors 15 to 50 hp, every 3 years; and motors 50 to 150 hp, yearly. For motors in a dusty or dirty environment or running 24 hours a day, divide the service interval by 2. If the environment is very dirty or high temperatures exist, divide the service interval by 4. Lubrication requirements are normally attached to the motor. Do not overlubricate.

Figure 9. Safety & Lubrication Instructions for Fans with Ball Bearings

WARNING

- This equipment must not be operated without proper guarding of all moving parts. While performing maintenance be sure remote power switches are locked off. See AMCA Publication 410 for recommended safety practices.
- Before starting: Check all setscrews for tightness, and rotate wheel by hand to make sure it has not moved in transit.

Relubrication Schedule (Months)* Ball Bearing Pillow Blocks									
Speed (RPM)	500	1000	1500	2000	2500	3000	3500	4000	4500
Shaft DIA									
1/2" thru 1 1/16"	6	6	5	3	3	2	2	2	1
1 1/16" thru 2 7/16"	6	5	4	2	2	1	1	1	1
2 1/16" thru 2 5/16"	5	4	3	2	1	1	1		
3 7/16" thru 3 5/16"	4	3	2	1	1	1			

* Suggested initial greasing interval: Relubricate while running, if safety permits, until some purging occurs at seals. Adjust lubrication frequency depending on condition of purged grease. Hours of operation, temperature, and surrounding conditions will affect the relubrication frequency required.

- Lubricate with a high quality NLGI No. 2 or No. 3 multipurpose ball bearing grease having rust inhibitors and antioxidant additives. Some greases having these properties are:
 Shell - Alvania No. 2 Mobil - Mobilith AW2/Mobilith SHC100
 Gulf - Gulfcrown No. 2 American - Rykon Premium 2
- Lubricate bearings prior to extended shutdown or storage and rotate shaft monthly to aid corrosion protection.

Figure 10. Safety & Lubrication Instructions for Fans with Unit Roller Bearings

WARNING

- This equipment must not be operated without proper guarding of all moving parts. While performing maintenance be sure remote power switches are locked off. See AMCA Publication 410 for recommended safety practices.
- Before starting: Check all setscrews for tightness, and rotate wheel by hand to make sure it has not moved in transit.

Relubrication Schedule (Months)* Spherical Roller Bearing - Solid Pillow Blocks									
Speed (RPM)	500	1000	1500	2000	2500	3000	3500	4000	4500
Shaft DIA									
1 3/16" thru 1 7/16"	6	4	4	2	1	1	1	1	1/2
1 1/16" thru 2 3/16"	4	2	1 1/2	1	1/2	1/2	1/2	1/2	1/2
2 7/16" thru 3 7/16"	3	1 1/2	1	1/2	1/2	1/4	1/4		
3 1/16" thru 4 1/16"	2 1/2	1	1/2	1/4					

*Suggested initial greasing interval: Relubricate while running, if safety permits, until some purging occurs at seals. Adjust lubrication frequency depending on condition of purged grease. Hours of operation, temperature, and surrounding conditions will affect the relubrication frequency required.

- Lubricate with a multipurpose roller bearing NLGI No. 2 having rust inhibitors and antioxidant additives, and a minimum oil viscosity of 500 SSU at 100°F. Some greases having these properties are:
 Shell - Alvania No. 2 Mobil - Mobilith AW2/Mobilith SHC100
 Texaco - Premium RB2 American - Rykon Premium 2
- Lubricate bearings prior to extended shutdown or storage and rotate shaft monthly to aid corrosion protection.

Figure 11. Safety & Lubrication Instructions for Fans with Split Roller Bearings

WARNING

- This equipment must not be operated without proper guarding of all moving parts. While performing maintenance be sure remote power switches are locked off. See AMCA Publication 410 for recommended safety practices.
- Before starting: Check all setscrews for tightness, and rotate wheel by hand to make sure it has not moved in transit.

Relubrication Schedule (Months)*										Grease to be added at each interval
Spherical Roller Bearing - Split Pillow Blocks										
Speed (RPM)	500	750	1000	1500	2000	2500	3000	3500	4000	
Shaft DIA										
1 7/16" thru 1 15/16"	6	4 1/2	4	4	3 1/2	2 1/2	2 1/2	1	1	0.50 oz.
2 3/16" thru 2 1/4"	5	4 1/2	4	2 1/2	2 1/2	1 1/2	1/2	1/4	1/4	0.75 oz.
2 15/16" thru 3 15/16"	4 1/2	4	3 1/2	2 1/2	1 1/2	1	1/2			2.00 oz.
4 7/16" thru 4 15/16"	4	4	2 1/2	1	1/2					4.00 oz.
5 1/16" thru 5 15/16"	4	2 1/2	1 1/2	1						7.00 oz.

*Suggested initial greasing interval - remove bearing cap and observe condition of used grease after lubricating. Adjust lubrication frequency as needed. Hours of operation, temperature, and surrounding conditions will affect the relubrication frequency required. Clean and repack bearings annually. Remove old grease, pack bearing full and fill housing reservoirs on both sides of bearing to bottom of shaft.

- Lubricate with a multipurpose roller bearing NLGI No. 2 having rust inhibitors and antioxidant additives, and a minimum oil viscosity of 500 SSU at 100°F. Some greases having these properties are:
 Shell - Alvania No. 2 Mobil - Mobilith AW2/Mobilith SHC100
 Texaco - Premium RB2 American - Rykon Premium 2
- Lubricate bearings prior to extended shutdown or storage and rotate shaft monthly to aid corrosion protection.

Static Oil Lubrication

- Use only highest quality mineral oil with a minimum viscosity of 100 SSU at the oil's operating temperature. The oil's operating temperature is approximately 10° greater than the bearing's housing. SAE values having this viscosity at the following operating temperature are:
 150° - SAE 20 160° - SAE 30 180° - SAE 40
- Static oil level should be at the center of the lower-most roller (Do not overfill.)
- Complete lubrication change should be made annually.

Drive Maintenance

V-belt drives need periodic inspection and occasional belt replacement. When inspecting drives, look for dirt buildup, burrs or obstructions which can cause premature belt or drive replacement. If burrs are found, use fine emery cloth or a stone to remove the burr. Be careful that dust does not enter the bearings.

Check the sheaves for wear. Excessive slippage of belts on sheaves can cause wear and vibration. Replace worn sheaves with new ones. Carefully align sheaves to avoid premature sheave failure.

Observe belts for wear. If fraying or other wear is observed to be mostly on one side of the belts, the drives may be misaligned. Reinstall the drives according to instructions given for Fan Installation – Disassembled Units. Never use belt dressing on any belts.

When replacing belts, replace the entire set. After initial replacement and tensioning, recheck belt tension after a few days to adjust belt tension again. (New belts require a break-in period of operation.)

Bearing Maintenance

For instructions covering special lubrication intervals, bearing assembly or disassembly, or installation details, see attached documents. Any bearing which is disassembled should be kept separate from other bearing

parts as components may not be interchangeable. Maintain cleanliness of components and bearings to prevent bearing contamination.

Bearing failure can occur from many causes. See Troubleshooting section for details.

Note: All speeds shown do not apply to all shaft sizes in that group. Consult the factory if in doubt of maximum speed for a particular bearing.

Lubrication

Proper lubrication of bearings helps assure maximum bearing life. All fans are equipped with decals indicating relubrication intervals for normal operating conditions. However, every installation is different and the frequency of lubrication should be established accordingly.

Experience has shown that airborne moisture and heavy dust will dramatically reduce the life of the bearing lubricant. If any of these adverse conditions exist, it is recommended that bearings be regreased after several days of operation. Lubrication intervals can then be adjusted based on the condition of the purged grease.

Figure 9 illustrates the decal for ball bearings, Figure 10 the decal for solid pillow block spherical roller bearings, and Figure 11 shows the decal for split pillow block spherical roller bearings. Observation of the condition of the grease expelled from the bearings at the time of relubrication is the best guide as to whether regreasing intervals and the amount of grease added should be altered. This observation is particularly important when bearings operate continuously over 160°F.

Greases are made with different bases. There are synthetic base greases, lithium base, sodium base, etc. Avoid mixing greases with different bases. They could be incompatible and result in rapid deterioration or breakdown of the grease.

All bearings are filled with grease before leaving the factory. When the fans are started, the bearings may discharge excess grease through the seals for a short period of time. Do not replace the initial discharge because leakage will cease when the excess grease has worked out. Sometimes the bearing has a tendency to run hotter during this period and one should not get alarmed unless it lasts over 48 hours or gets above 220°F. When relubricating, use a sufficient amount of grease to purge the seals. Rotate bearings during relubrication where good safety practice permits.

For bearings with oil lubrication, sight gauges are installed so that a proper level can be reviewed and maintained. Sight gauges should be read with bearings not rotating.

Wheel and Shaft Maintenance

Periodically inspect the shaft and wheel for dirt buildup, corrosion, and signs of excess stress or fatigue. Clean the components and, when appropriate, apply new coatings. (Any addition of coatings or weld can create an imbalance.) Check the balance of the assembly.

Structural Maintenance

All structural components or devices used to support or attach the fan to a structure should be checked at regular intervals. Vibration isolators, bolts, foundations, etc., are subject to failure from corrosion, erosion, and other causes. Improper mounting can lead to poor operation characteristics or fan fatigue and failure.

Check metallic components for corrosion, cracks, or other signs of stress. Concrete should be checked to ensure the structural integrity of the foundation.

Troubleshooting Guidelines

Use current safety practices when investigating fan or system performance problems. General safe practices and performance troubleshooting guidelines can be found in AMCA Publications 410 and 202, respectively. Fan application and field measurement procedures can be found in AMCA Publications 201 and 203.

Troubleshooting Performance Problems

The lists below indicate possible areas to check when air or sound values do not match expectations. Most fan problems can be pinpointed to one of these common causes.

Air Capacity Problems:

1. Resistance of system not at design rating. If resistance is lower than expected, both airflow and horsepower may be up. If resistance is higher than anticipated, air volume will be down.
2. Fan speed is not at design speed.
3. Air density not at design values. Also check air performance measurement techniques/procedures.
4. Devices for air modulation are closed or plugged. Also check filters.
5. Wheel mounted improperly or is rotating in reverse.
6. Parts of system or fan have been damaged or need cleaning.

Noise Problems:

1. Air performance is incorrect and fan is not at design point of operation. Fan forced to operate in an unstable flow region.
2. Bearing failure. Check bearings (lubrication).
3. Supply voltage high or inconsistent supply frequency. Adjustable frequency controllers can generate motor noise.
4. Objects which are installed in a high velocity airstream can generate noise. This includes flow sensors, turning vanes, etc.
5. Poor fan inlet conditions.
6. Acoustics or sound measurement procedure incorrect.

Vibration Problems:

1. Misalignment of drive components.
2. Poor foundations or mounting structure (resonances).
3. Foreign material attached to rotating components.
4. Damaged rotating components (bearings, shaft, fan, wheel, sheaves).
5. Broken, loose or missing setscrews.
6. Loose bolts.
7. Vibration transmitted by another source.
8. Water accumulating in airfoil blades.
9. Fan is operating in stall or unstable flow region.

NOTE: All fans manufactured by Twin City Fan & Blower are factory balanced prior to shipment. Handling and movement of the fan during shipment may cause the rotating assembly to shift. Balance should be checked once the fan is installed. If a final trim balance is required, it is the end user's responsibility to bring the fan back to factory specifications. Final trim balancing is not the responsibility of Twin City Fan & Blower.

Motor Problems:

1. Incorrect wiring.
2. Speed of fan too high.
3. Parts improperly installed - binding.
4. Bearings improperly lubricated.
5. WR² capability of motor too low for application.
6. Protection devices may be improperly sized.

Drive Problems:

1. Belts improperly tensioned.
2. Drive alignment is poor.

Bearing Problems:

Generally speaking, Twin City Fan & Blower uses three types of bearings:

1. Ball bearing with set screw lock.
2. Spherical roller bearings with set screw lock.
3. Spherical roller bearings with adapter lock/taper lock feature to attach them to the shaft.

Ball bearings – These are self-aligning bearings and should present no alignment problems with one exception: i.e., on Sealmaster bearings there is a pin beneath the grease fitting which prevents the bearings outer race from rotating. Should this pin jam, the bearing loses its alignment feature.

Common failure causes are (1) set screws loosening and shaft turning within the bearing, and (2) crowned bearing supports. Loosen one bolt and measure the clearance between the pillow block and the support. Add shim to compensate.

Spherical Roller Bearings with Set Screw Lock – The self-aligning characteristic of these bearings are inherent in the spherical roller design. The closer that these bearings are to perfect alignment, the cooler they will operate.

Common failure causes are the same as with ball bearings, mainly set screws loosening and crowned bearing supports.

Spherical Roller Bearings with Adapter Lock – Again, the self-aligning feature is inherent in the spherical design. Good alignment results in a cooler operating bearing. The faster the bearing operates the more critical this becomes.

A common cause of failure is improper installation practice. Removing too much clearance from the bearing can result in preloading the bearing, resulting in premature failure; and removing not enough can result in the shaft rotating within the bearing. Properly tightened, this method of attaching a bearing to a shaft is second only to a press fit. Crowned bearing supports can also preload these bearings and should be checked by loosening one side of the bearing and checking for clearance.

Lubrication – The major cause of bearing failure is contamination of grease, insufficient grease, or incompatibility of grease. If a fan is to be stored for any length of time at the job site, the bearings immediately should be filled with grease while rotating the shaft and then the bearings should be regreased and rotated monthly. This will prevent moisture, which condenses within the bearing, from corroding the raceways. Most greases used on fan pillow blocks are lithium base. Use the greases shown on the bearing decal. Do not mix the bases without completely purging out the initial grease.

Initially, follow the lubrication instruction on the side of the fan. The frequency of lubrication should be adjusted depending on the condition of the old grease being purged. This is the responsibility of the user. If the grease is dirty, the lubrication frequency should be more often.

- a. Noise – If a bearing is increasing in noise intensity and/or vibration, it will probably result in failure.
- b. Temperature – If a bearing temperature begins to gradually rise, it will generally result in failure. A bearing can operate up to 200 degrees and operate satisfactorily if the temperature remains constant and the bearing receives adequate lubrication. Remember that a roller bearing under the same load and speed will be somewhat more noisy and run warmer than a ball bearing. This is normal.

Rough handling and/or dropping a fan can result in brinelling the bearing. This appears as a clicking noise at first, then gradually worsens until failure.

When replacing a bearing, always align the bearings first, then bolt the pillow blocks to their support, rotate the shaft, fasten the bearings to it. If the bearing is fastened to the shaft first, tightening the pillow block bolts may bind the shaft and preload the bearings.

Limitation of Warranties and Claims

Seller warrants to the original purchaser that the goods sold hereunder shall be free from defects in workmanship and material under normal use and service (except in those cases where the materials are supplied by the buyer) for a period of one year from the date of original installation or eighteen (18) months from the date of shipment, whichever occurs first. The liability of seller under this warranty is limited to replacing, repairing, or issuing credit (at cost, F.O.B. factory and at seller's discretion) for any part or parts which are returned by buyer during such period provided that:

- a. seller is notified in writing within ten (10) days following discovery of such defects by buyer, or within ten (10) days after such defects should reasonably have been discovered, whichever is less;

- b. the defective unit is returned to seller, transportation charges prepaid by buyer.
- c. payment in full has been received by seller or said products; and
- d. seller's examination of such unit shall disclose to its satisfaction that such defects have not been caused by misuse, neglect, improper installation, repair, alteration, act of God, or accident.
- e. seller cannot guarantee sound pressure levels or dBA.

No warranty made hereunder shall extend to any seller product whose serial number is altered, effaced or removed. Seller makes no warranty, express or implied, with respect to motors, switches, controls, or other components of seller's product, where such components are warranted separately by their respective manufacturers. THIS WARRANTY IS EXPRESSLY IN LIEU OF ALL OTHER WARRANTIES, EXPRESS OR IMPLIED, WHETHER STATUTORY OR OTHERWISE, INCLUDING ANY IMPLIED WARRANTY OF MERCHANTABILITY OR FITNESS FOR A PARTICULAR PURPOSE. In no event shall seller be liable to buyer for indirect, incidental collateral, or consequential damages of any kind. (BUYER'S FAILURE TO PAY THE FULL AMOUNT DUE WITHIN SIXTY (60) DAYS OF DATE OF INVOICE SHALL OPERATE TO RELEASE SELLER FROM ANY AND ALL LIABILITY OR OBLIGATION ARISING PURSUANT TO ANY WARRANTY, EXPRESS OR IMPLIED, WHETHER STATUTORY OR OTHERWISE, INCLUDING ANY IMPLIED WARRANTY OR MERCHANTABILITY OR FITNESS FOR A PARTICULAR PURPOSE, MADE IN CONNECTION WITH ANY CONTRACT FORMED HEREUNDER. BUYER AGREES THAT SUCH FAILURE TO PAY SHALL CONSTITUTE A VOLUNTARY WAIVER OF ANY AND ALL SUCH WARRANTIES ARISING PURSUANT TO SUCH CONTACT.)



Twin City Fan & Blower

A Twin City Fan Company

5959 Trenton Lane · Minneapolis, MN 55442-3237

Phone (763) 551-7600 · Fax (763) 551-7601 · www.tcf.com

