



Twin City Fan & Blower

INSTALLATION, OPERATION & MAINTENANCE MANUAL

Aero Acoustic Diffuser™

ENGINEERING SUPPLEMENT

ES-409

Issue Date: 06-29-10

Rev. Date: NEW

Contents

Introduction	1
Shipping	1
Handling	1
Storage	1
Parts List	1
Aero Acoustic Diffuser™ Installation.....	2
Aero Acoustic Diffuser™ Operation Safety.....	2
Operation Checklist.....	3
Maintenance.....	3
Troubleshooting Guidelines.....	3
Limitation of Warranties and Claims	3

Introduction

The purpose of this manual is to provide instructions that complement good general practices when installing or operating Twin City Fan & Blower's Aero Acoustic Diffuser™ originally provided on the E-Series Plenum Fan or purchased as an accessory after purchasing the E-Series plenum fan.

Instructions given in the body of this manual are general in nature, but apply to only to the E-Series plenum fan manufactured by Twin City Fan & Blower.

Shipping and Receiving

All Twin City Fan & Blower products are carefully constructed and inspected before shipment to insure the highest standards of quality and performance.

Compare all the components with the bill of lading or packing list to verify the proper unit was received.

Check each unit for any damage that may have occurred in transit. Any damage should be reported immediately to the carrier and the necessary damage report filed.

Handling

Handling of all air moving equipment should be conducted by trained personnel and be consistent with safe handling practices. Verify the lift capacity and operating condition of handling equipment. Maintain handling equipment to avoid serious personal injury.

Units shipped completely assembled, mounted to the fan, require minimal handling. Use only designated lifting lugs on fan framework for handling the fan.



Partial or disassembled units require special handling. All parts should be handled in a fashion that protects the parts from damage. Components should be handled such that forces are not concentrated and bending or distortion cannot occur.

Aero Acoustic Diffusers™ should be lifted using straps or padded chains if necessary. Do not distort the components when lifting. Deformed components are a source of interference between the fan impeller and the Aero Acoustic Diffuser™ resulting in excessive noise and possibly fan impeller imbalance.

Storage

If the Aero Acoustic Diffuser™ installation is to be delayed, store the unit in an indoor, protected area. Protect the Aero Acoustic Diffuser™ from moisture and possible incidental contact. A temperature controlled storage facility is preferred.

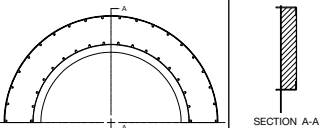
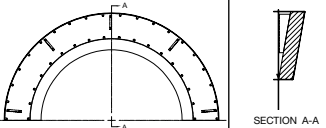
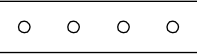
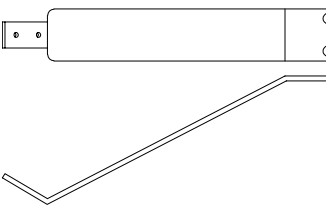
Parts List

Item	Qty	Part Name	Sketch
1	1	Backplate Diffuser (Two (2) Halves)	
2	1	Frontplate Diffuser (Two (2) Halves)	
3	4	Diffuser End Connector	
4	8	Diffuser Mounting Brackets	
5	48	1/4"-20 Self Tap Screws	N/A
6	16	3/8"-16 Bolt & Nut	N/A
7	4 (Only required for Sizes 300 to 807)	Diffuser Side Connector	

Aero Acoustic Diffuser™ Installation

Follow the proper handling instructions given earlier. If mounting slots are not supplied, proceed to Step 1; if mounting slots are supplied on fan, proceed to Step 3:

- Using the formulas below, calculate mounting hole locations. (See Figure 1):
 - “A” = Measured in the field. (Distance from inside frame to impeller backplate)
 - “B” = Measured in the field. (Distance from impeller backplate to impeller frontplate)
 - “C” = “A”-1.40
 - “D” = “A”+“B”+“F”
 - “E” = See Table 1
 - “F” = See Table 1
- Measure, mark and drill mounting bracket holes as shown (See Figure 1). Note: Holes are required on both sides of fan on the top and bottom frame rails for sixteen (16) holes. Lifting lugs may need to be removed.

Table 1.

Size	E	F	Size	E	F
122	0.89	0.03	365	1.19	0.15
150	0.89	0.00	402	1.19	0.16
165	0.89	0.00	445	1.19	0.15
182	0.93	0.16	490	1.19	0.15
200	0.93	0.13	542	1.19	0.12
222	1.13	0.13	600	1.19	0.46
245	1.13	0.19	660	1.19	0.58
270	1.13	0.16	730	1.19	0.41
300	1.13	0.16	807	1.19	0.31
330	1.13	0.16			

Figure 1.

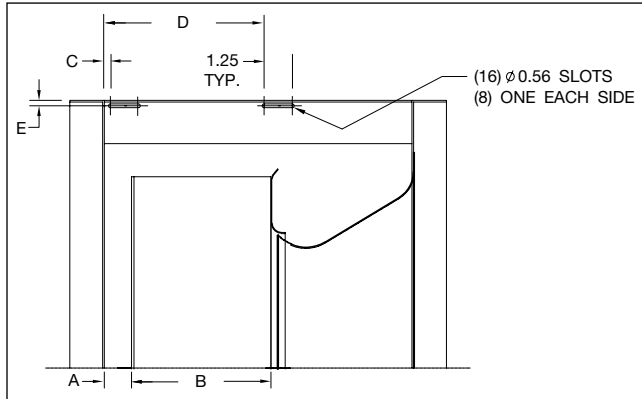

- If not done so, separate backplate diffuser and frontplate diffuser into two (2) halves by removing connector brackets provided. Four (4) diffuser pieces will result. (See Figure 2)

Figure 2.

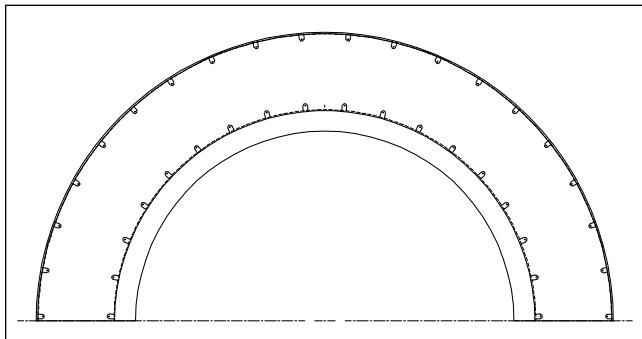

- Insert each diffuser section into the fan frame. As shown in Figure 3. The backplate diffuser mounts on backplate side of impeller; the frontplate diffuser mounts on the frontplate side of impeller. Note: Perforated side of diffuser sections must be in the air path (see Figure 3).

Figure 3.

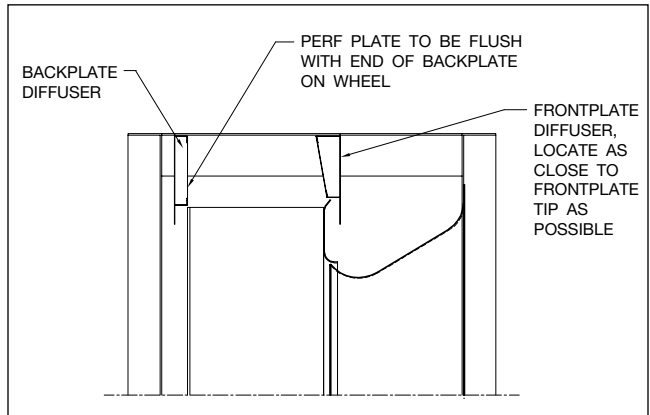

- With the four (4) diffuser sections located inside the fan framework, use the screws and connector brackets removed in Step 3 to reassemble the two (2) diffuser halves back together as shown in Figure 4.

Figure 4.

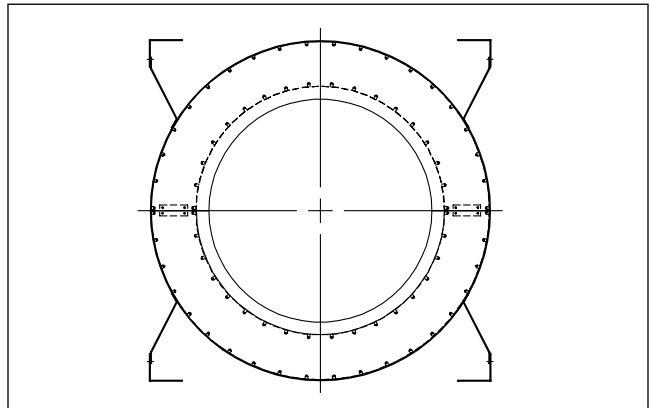
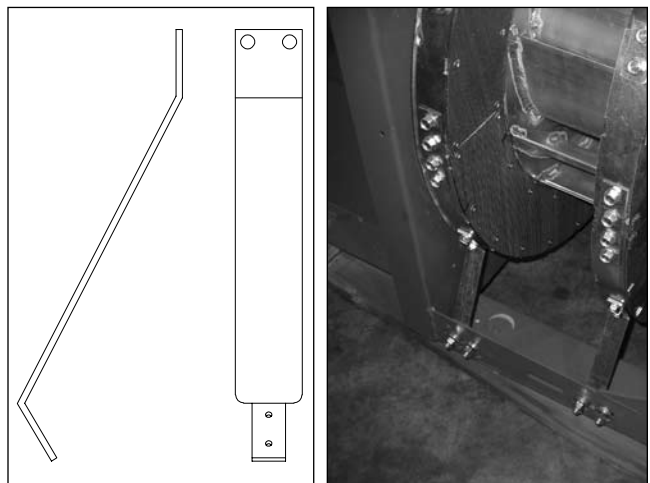

Figure 5.



6. Attach mounting brackets to diffuser using 1/4" self-tapping screws. Make sure that the narrower end is installed on diffuser and that the wider end is inside the fan frame (see Figure 5).
7. Attach mounting brackets to fan frame using the existing slots or the holes drilled in Step 1. Hand-tighten 3/8" bolts and nuts (see Figure 5).
8. Align diffuser as shown in Figure 3 and fully tighten all hardware. Motor or bearings may need adjusting (see Figure 3).

Aero Acoustic Diffuser™ Operation - Safety

For general safety practices for air moving equipment, see AMCA Bulletin 410.

Twin City Fan & Blower has many safety accessories available. These safety devices include (but are not limited to) belt guards, shaft guards, inlet and discharge screens. The use, abuse or non-use of safety devices is the responsibility of the purchaser.

Facility-related safety conditions include fan accessibility and location. How easily can non-service personnel access the unit? Is the fan in a hazardous duty environment? Was the unit ordered for this duty? Other concerns must also be addressed. All fans should be powered through switches which are easily accessible to service personnel from the fan. Every switch should have the ability to be "locked-off" by the service person and the key to be retained by this person to prevent accidental power of the fan while service is in process.

WARNING: NEVER INSTALL, ASSEMBLE, ADJUST OR REMOVE Aero Acoustic Diffuser™ while fan is in operation. Twin City Fan & Blower requires fan to be "locked-off" while any maintenance is performed.

Operation Checklist

- Verify that proper safety precautions have been followed.
 - Electrical power must be locked off.
- Check fan mechanism components:
- Aero Acoustic Diffuser™ connections are properly made and tightened.
 - Aero Acoustic Diffuser™ sections are properly assembled and tightened.
 - Impeller and Aero Acoustic Diffuser™ surfaces are clean and free of debris.
 - Rotate the impeller by hand to verify it has not shifted in transit or assembly.
 - Check Aero Acoustic Diffuser™ / impeller alignment. See Figures 3.
 - Verify backplate and frontplate diffusers are on correct side of impeller (not reversed). See Figure 3.
 - Check that perforation of diffusers are on the airpath side impeller.

Trial "bump":

- Turn on power just long enough to start assembly rotating.
 - Verify the impeller and Aero Acoustic Diffuser™ assembly do not rub.
 - Correct any problems which may have been found. (Follow safety guidelines - shut power off.) Perform checklist again until unit is operating properly.
 - Run unit up to speed.
- Verify fastener tightness. These may have loosened during shipment or installation:
- After one week of operation, check all nuts, bolts and tighten if necessary.

Maintenance of Aero Acoustic Diffuser™

This section contains general maintenance instructions for your Twin City Fan & Blower Aero Acoustic Diffuser™.

Aero Acoustic Diffuser™ Maintenance

Periodically inspect Aero Acoustic Diffuser™ for signs of excess stress or fatigue. Clean the surfaces when appropriate. **WARNING: DO NOT APPLY LIQUIDS DIRECTLY TO THE AERO ACOUSTIC DIFFUSER™ AS A METHOD OF CLEANING. DIRECT APPLICATION OF LIQUIDS CAN GENERATE POTENTIALLY HAZARDOUS CONDITIONS.**

Structural Maintenance

All structural components or devices used to support or attach the Aero Acoustic Diffuser™ to the fan should be checked at regular intervals. Improper mounting can lead to poor operation characteristics or diffuser fatigue and failure. Check mounting components for corrosion, cracks or other signs of stress.

Limitation of Warranties and Claims

Seller warrants to the original purchaser that the goods sold hereunder shall be free from defects in workmanship and material under normal use and service (except in those cases where the materials are supplied by the buyer) for a period of one year from the date of original installation or eighteen (18) months from the date of shipment, whichever occurs first. The liability of seller under this warranty is limited to replacing, repairing, or issuing credit (at cost, F.O.B. factory and at seller's discretion) for any part or parts which are returned by buyer during such period provided that:

- a. seller is notified in writing within ten (10) days following discovery of such defects by buyer, or within ten (10) days after such defects should reasonably have been discovered, whichever is less;
- b. the defective unit is returned to seller, transportation charges prepaid by buyer.
- c. payment in full has been received by seller or said products; and
- d. seller's examination of such unit shall disclose to its satisfaction that such defects have not been caused by misuse, neglect, improper installation, repair, alteration, act of God, or accident.
- e. seller cannot guarantee sound pressure levels or dBA.

No warranty made hereunder shall extend to any seller product whose serial number is altered, effaced or removed. Seller makes no warranty, express or implied, with respect to motors, switches, controls, or other components of seller's product, where such components are warranted separately by their respective manufacturers. THIS WARRANTY IS EXPRESSLY IN LIEU OF ALL OTHER WARRANTIES, EXPRESS OR IMPLIED, WHETHER STATUTORY OR OTHERWISE, INCLUDING ANY IMPLIED WARRANTY OF MERCHANTABILITY OR FITNESS FOR A PARTICULAR PURPOSE. In no event shall seller be liable to buyer for indirect, incidental collateral, or consequential damages of any kind. (BUYER'S FAILURE TO PAY THE FULL AMOUNT DUE WITHIN SIXTY (60) DAYS OF DATE OF INVOICE SHALL OPERATE TO RELEASE SELLER FROM ANY AND ALL LIABILITY OR OBLIGATION ARISING PURSUANT TO ANY WARRANTY, EXPRESS OR IMPLIED, WHETHER STATUTORY OR OTHERWISE, INCLUDING ANY IMPLIED WARRANTY OR MERCHANTABILITY OR FITNESS FOR A PARTICULAR PURPOSE, MADE IN CONNECTION WITH ANY CONTRACT FORMED HEREUNDER. BUYER AGREES THAT SUCH FAILURE TO PAY SHALL CONSTITUTE A VOLUNTARY WAIVER OF ANY AND ALL SUCH WARRANTIES ARISING PURSUANT TO SUCH CONTACT.)



Twin City Fan & Blower

A Twin City Fan Company

5959 Trenton Lane · Minneapolis, MN 55442-3237
Phone (763) 551-7600 · Fax (763) 551-7601 · www.tcf.com

