

Twin City Fan & Blower

AXIPAL[®] ADJUSTABLE PITCH AIRFOIL FANS

TYPE ATAD / ATAB



AXIPAL[®] Adjustable Pitch Airfoil Design

Model ATAD

Arrangement 4 – Direct Drive

- Available in ten sizes from 14" (035) to 49" (125) in diameter.
- Capacity from 500 to 75,000 CFM and pressures to 4½" w.g.
- Standard fan/motor configuration is suitable for maximum air temperature of 104°F. Special motors are available for higher temperature applications. Please consult the factory for assistance.



Model ATAB

Arrangement 9 – Belt Driven

- Available in nine sizes from 16" (040) to 49" (125) in diameter.
- Capacity from 2,400 to 65,000 CFM and pressures to 2½" w.g.
- Standard fan configuration is suitable for a maximum temperature of 275°F.



Contents

Construction Features	3
Accessories	4
Mounting Arrangements	5
Fan Selection	6
Temperature and Altitude Correction	6
Performance Data	
Arrangement 4 – Direct Drive.	7
Arrangement 9 – Belt Driven	17
Dimensional Data	
Inlet Bell/Inlet & Outlet Cone	19
Arrangement 4 – Direct Drive.	20
Arrangement 9 – Belt Driven	22
Typical Specifications	
Arrangement 4 – Direct Drive.	21
Arrangement 9 – Belt Driven	23

Certification



Twin City Fan & Blower certifies that the models ATAD and ATAB shown herein are licensed to bear the AMCA Seal for Sound and Air. The ratings shown are based on tests and procedures performed in accordance with AMCA Publication 211 and AMCA Publication 311 and comply with the AMCA Certified Ratings Program.

Refer to Bulletin AX211 for sound power levels.

©2003 Twin City Fan Companies, Ltd. All rights reserved throughout the world.

Bulletin illustrations cover the general appearance of products at the time of publication and we reserve the right to make changes in design and construction at any time without notice.

Construction Features

Design Innovation

AXIPAL® fan blades have an ever-increasing airfoil chord length from the blade root to the blade tip. The additional chord length is placed at the leading edge rather than the trailing edge of the blade so that when set at an angle, the widest part of the airfoil is at maximum rotational speed in close proximity to the fan casing. This very wide blade tip area allows the AXIPAL® to maximize energy transfer to the airstream and minimize noise generation.

The blade pitch can be individually manually adjusted while the fan is stopped. This feature allows the user to balance the present system while affording the flexibility of further possible pitch adjustment in the future.

Propeller Construction

The blades are made of permanent mold A319 aluminum alloy castings for high strength and precision. Retaining bolts hold the root of the blade casting in position in a spherical pocket between two stamped carbon steel hub plates. The hub center boss is made of cast iron and is straight bored and keyed for direct attachment to motor or fan shafts or, in fans of 24" diameter and larger, is fitted with a taper-lock bushing.

Housing

AXIPAL® housings are made of continuously welded, heavy-gauge carbon steel with integrally rolled inlet and outlet flanges. Integral flanges are provided with bolt holes for bolting to fan accessories or ductwork. Housings can be supported by bolting the integral flanges directly to ductwork or can be provided with bolted support legs or welded clips for mounting in a horizontal or vertical position. After fabrication the housing is chemically pretreated, phosphatized, and painted with two coats of air dried acrylic enamel.

Extended grease fittings and grease leads are standardly furnished to permit relubrication of the motor bearings at the exterior of the fan housing. Motor leads are extended through liquid-tight conduit to the exterior of the fan housing to facilitate wiring.

Standard NEMA foot-mounted motors, of open drip-proof, totally enclosed or explosion-proof design are used on direct drive fans. Motors are squirrel cage induction, single speed, single winding, variable torque type for continuous duty operation.

Belt Driven Design

Well suited for applications where it is advantageous to have the motor out of the airstream due to the presence of corrosive or hazardous fumes, or dirt-laden, hot, or moist air, Arrangement 9 fans include the following features as standard equipment:

- Belts and driven sheave enclosed in a metal tube protected from the airstream.
- Single jackscrew belt tension adjustment (see detail below).
- Standard NEMA foot-mounted motors, of open drip-proof, totally enclosed or explosion-proof design are used on belt driven fans. Motors are squirrel cage induction, single speed, single winding, variable torque type for continuous duty operation.

Adjusting Belt Tension

All belt driven units are constructed with the motor base plate welded to the outside of the fan casing which provides strength and rigidity. Except for very small motors, the adjustment of the belt tension is accomplished by means of a jackscrew as shown in the illustration below. This arrangement permits adjustment to be made with a minimum of effort, particularly when the motor is of large size.

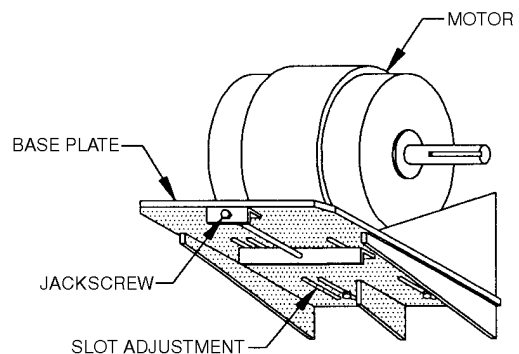

Accessories

Inlet Bell

A spun steel aerodynamic inlet bell (necessary to minimize inlet losses on installations where ductwork does not precede the fan) shown bolted to fan inlet flange with an inlet guard of spiral wire bolted to inlet bell to provide personnel safety protection.



Curb Base

A square-to-round transition piece to convert an axial fan to a roof ventilator when mounted between a roof curb and the fan inlet flange. A stack cap or other device is necessary for weather protection in installations of this type.



Shaft Seal

An elastomeric viton rotary seal rides against a heavy Teflon, bolted-in-place, wear plate which surrounds the shaft of belt driven fans to provide protection of the shaft and bearings when handling dirty, wet or corrosive air. Note: The seal does not make the installation gas-tight and is not appropriate in ambient temperatures above 250°F.



Stack Cap

A backdraft damper assembly bolted to the fan discharge flange in vertical upblast rooftop installations. Ideally this device should be selected to handle discharge velocities ranging from 1800 to 3000 FPM and will add approximately 1/8" pressure drop to system.



Motor Cover

A vented cover bolted to the exterior of a belt driven fan to provide drip-proof protection of the motor and drive tube when units are installed outdoors in horizontal or vertical configuration. Note: The standard belt guard is not provided when a motor cover is specified.

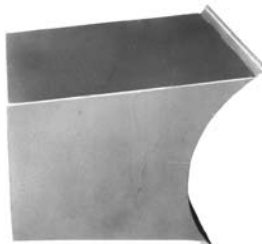

Mounting Arrangements

Following are the mounting arrangements for AXIPAL® fans. Please specify the mounting arrangement required at time of order.

Example 1: For a belt driven fan with mounting arrangement horizontal floor mounted and motor on top, specify “top.”

Example 2: For a direct drive fan with mounting arrangement horizontal floor mounted, specify “support legs.”

Example 3: For a belt driven fan with mounting arrangement floor down discharge, specify “SA2”.

Belt Driven Fans

Horizontal Floor Mounted

(view from outlet)

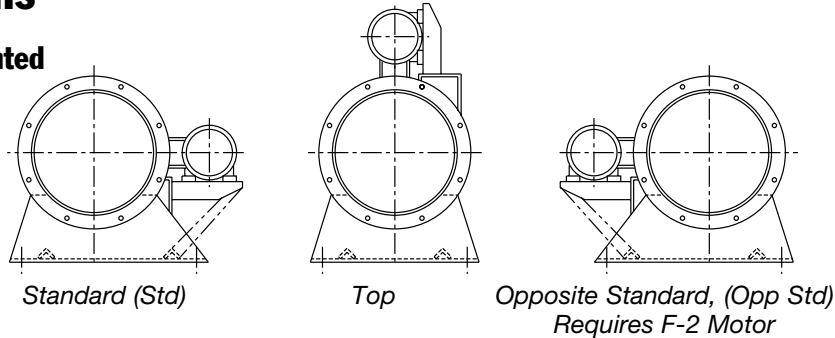

Vertical Floor & Ceiling Mounted

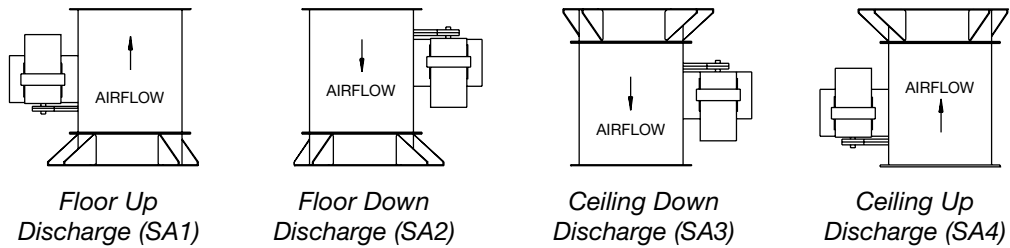

Horizontal Ceiling Mounted

(view from outlet)

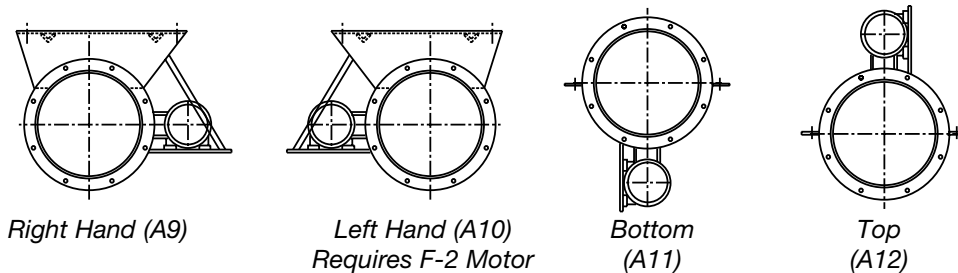

Direct Drive Fans

Horizontal Floor

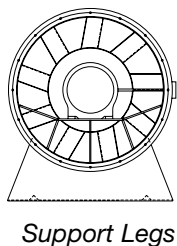

Ceiling Horizontal Discharge

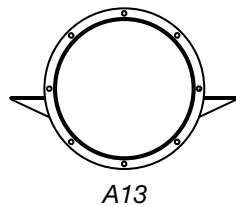

Vertical Floor & Ceiling Mounted

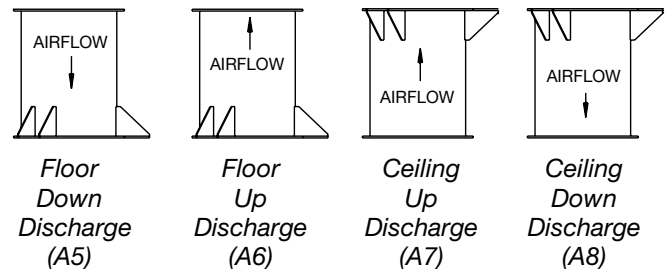

Fan Selection

Present methods of testing fans provide accurate, dependable performance data; however, information available for designing systems is necessarily based on averages. Therefore, a certain amount of “rounding off” of design figures is a reasonable approach and will produce a practical air handling system design. Most engineers prefer the static pressure or friction loss method of calculation.

The fan is usually located somewhere within the system; therefore, it is only necessary to figure the entrance loss and the duct friction loss, then select the fan directly from the tables. This method assumes that the duct size from the outlet of the fan to where the air is released to atmosphere is essentially the same as the diameter of the fan.

- If the fan is at the beginning of the duct, then an inlet bell should be used and no entrance loss is calculated.
- If the fan is at the end of the duct, then the entrance loss and duct friction are calculated and this is the fan static pressure.
- If an outlet cone is used and there is a static regain, the regain can be added to the static pressure.

Some systems are designed using total pressure (TP). Using the following formulas, the total pressure can be calculated.

Fan Selection Formulas

$VP = \left(\frac{CFM}{AREA \times 4005} \right)^2$	NOTE: This formula is used only for density at standard air, 0.075 lbs./ft ³ , 70°F and sea level.	Where: VP = Velocity pressure, IWG SP = Static pressure, IWG TP = Total pressure, IWG OV = Fan outlet velocity, FPM AREA = Fan outlet area, Ft ²
$VP = \left(\frac{CFM}{AREA \times 1096.7} \right)^2 \times \text{Density in lbs.per ft}^3$	NOTE: This formula is used when density is other than standard.	
TP = VP + SP		
$OV = \left(\frac{CFM}{AREA} \right)$		

Temperature and Altitude Correction

The performance tables in this bulletin are based on standard air density: 70°F at sea level (0.075 lbs./cu.ft. density). The fan performance tables provide the fan RPM and brake horsepower requirements for the given CFM and static pressure, at standard air density.

When the fan performance is not at standard conditions, the performance must be converted to standard conditions before entering the fan performance tables. The fan performance is converted to standard conditions by using the “Temperature and Altitude Density Ratio” from the table shown below.

Temperature and Altitude Density Ratios

AIR TEMP °F	ALTITUDE IN FEET ABOVE SEA LEVEL											
	0	1000	2000	3000	4000	5000	6000	7000	8000	9000	10000	15000
	BAROMETRIC PRESSURE IN INCHES OF MERCURY											
	29.92	28.86	27.82	26.82	25.84	24.90	23.98	23.09	22.22	21.39	20.58	16.89
-50	1.293	1.247	1.201	1.159	1.116	1.076	1.036	0.997	0.960	0.924	0.889	0.729
0	1.152	1.111	1.071	1.032	0.995	0.959	0.923	0.889	0.856	0.824	0.792	0.650
50	1.039	1.003	0.967	0.932	0.897	0.864	0.833	0.801	0.772	0.743	0.715	0.586
70	1.000	0.964	0.930	0.896	0.864	0.832	0.801	0.772	0.743	0.714	0.688	0.564
100	0.946	0.912	0.880	0.848	0.818	0.787	0.758	0.730	0.703	0.676	0.651	0.534
150	0.869	0.838	0.808	0.770	0.751	0.723	0.696	0.671	0.646	0.620	0.598	0.490
200	0.803	0.774	0.747	0.720	0.694	0.668	0.643	0.620	0.596	0.573	0.552	0.453
250	0.747	0.720	0.694	0.669	0.645	0.622	0.598	0.576	0.555	0.533	0.514	0.421
300	0.697	0.672	0.648	0.624	0.604	0.580	0.558	0.538	0.518	0.498	0.480	0.393
350	0.654	0.631	0.608	0.586	0.565	0.544	0.524	0.505	0.486	0.467	0.450	0.369
400	0.616	0.594	0.573	0.552	0.532	0.513	0.493	0.476	0.458	0.440	0.424	0.347
450	0.582	0.561	0.542	0.522	0.503	0.484	0.466	0.449	0.433	0.416	0.401	0.328
500	0.552	0.532	0.513	0.495	0.477	0.459	0.442	0.426	0.410	0.394	0.380	0.311
550	0.525	0.506	0.488	0.470	0.454	0.437	0.421	0.405	0.390	0.375	0.361	0.296
600	0.500	0.482	0.465	0.448	0.432	0.416	0.400	0.386	0.372	0.352	0.344	0.282

Performance Data – Direct Drive Model ATAD

Catalog Numbering System

To identify a specific fan for ordering or engineering specifications, it is necessary to show the complete information listed in the tables below under “catalog number.” All performance data is available in curve form upon request.

The model ATAD fans shown herein have been tested in accordance with ASHRAE 51-85 and AMCA 210-85 Test Code and are guaranteed by the manufacturer to deliver rated performance.

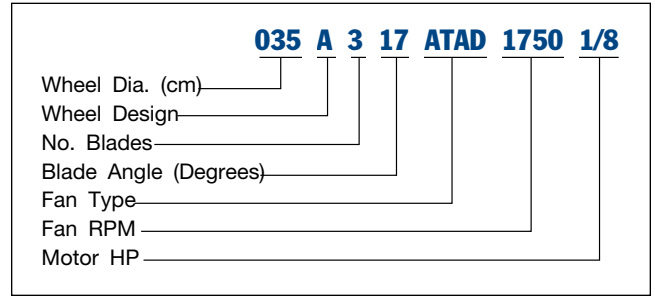

Size 035A ATAD – 1750 RPM

CATALOG NUMBER				CU. FT. PER MIN. & HP @ STATIC PRESSURE									
PROP	TYPE	RPM	HP	1/8" SP		1/4" SP		3/8" SP		1/2" SP		5/8" SP	
				CFM	BHP	CFM	BHP	CFM	BHP	CFM	BHP	CFM	BHP
3-BLADE													
035A307	ATAD	1750	1/12	783	0.06	492	0.06						
035A312	ATAD	1750	1/12	1021	0.08	785	0.08						
035A317	ATAD	1750	1/8	1287	0.10	1056	0.11						
035A322	ATAD	1750	1/8	1505	0.13	1256	0.13						
035A327	ATAD	1750	1/6	1749	0.17	1487	0.18						
035A332	ATAD	1750	1/4	1912	0.22	1615	0.21	1190	0.20				
035A337	ATAD	1750	1/4	2049	0.27	1728	0.26						
6-BLADE													
035A607	ATAD	1750	1/12	795	0.09	618	0.09	410	0.08				
035A612	ATAD	1750	1/8	1137	0.12	1000	0.13	670	0.12				
035A617	ATAD	1750	1/6	1397	0.15	1262	0.16	1085	0.17				
035A622	ATAD	1750	1/4	1661	0.19	1524	0.20	1353	0.22				
035A627	ATAD	1750	1/4	1939	0.25	1788	0.26	1604	0.27				
035A632	ATAD	1750	1/2	2174	0.30	1998	0.32	1783	0.32				
035A637	ATAD	1750	1/2	2423	0.39	2218	0.39	1960	0.39				

Size 035A ATAD – 3500 RPM

CATALOG NUMBER				CUBIC FEET PER MINUTE AND HORSEPOWER AT STATIC PRESSURE															
PROP	TYPE	RPM	HP	1/4" SP		1/2" SP		3/4" SP		1" SP		1 1/4" SP		1 1/2" SP		2" SP		2 1/2" SP	
				CFM	BHP	CFM	BHP	CFM	BHP	CFM	BHP	CFM	BHP	CFM	BHP	CFM	BHP	CFM	BHP
3-BLADE																			
035A307	ATAD	3500	1/2	1761	0.47	1566	0.48	1348	0.48	985	0.45								
035A312	ATAD	3500	3/4	2228	0.58	2042	0.60	1831	0.63	1570	0.63								
035A317	ATAD	3500	1	2751	0.77	2574	0.81	2355	0.84	2111	0.85	1773	0.85						
035A322	ATAD	3500	1	3194	0.99	3010	1.02	2771	1.06	2511	1.08	2175	1.07						
035A327	ATAD	3500	1 1/2	3688	1.36	3498	1.40	3263	1.42	2973	1.43	2617	1.40						
035A332	ATAD	3500	2	4046	1.71	3824	1.73	3547	1.73	3229	1.72	2864	1.68	2379	1.60				
035A337	ATAD	3500	2	4359	2.14	4097	2.13	3787	2.11	3456	2.07	3053	2.00						
6-BLADE																			
035A607	ATAD	3500	3/4	1729	0.73	1590	0.73	1425	0.73	1236	0.71	1047	0.70	819	0.66				
035A612	ATAD	3500	1	2390	0.90	2274	0.95	2147	0.99	2000	1.02	1806	1.04	1340	0.96				
035A617	ATAD	3500	1 1/2	2914	1.13	2794	1.19	2665	1.25	2523	1.31	2363	1.35	2171	1.38				
035A622	ATAD	3500	2	3450	1.43	3322	1.50	3187	1.56	3048	1.63	2894	1.68	2705	1.72				
035A627	ATAD	3500	2	4013	1.90	3878	1.97	3733	2.04	3575	2.10	3400	2.15	3208	2.18				

Performance certified is for installation type D: Ducted inlet, ducted outlet.
Performance ratings do not include the effects of appurtenances (accessories).

Performance Data – Direct Drive Model ATAD

Size 040A ATAD – 1160 RPM

CATALOG NUMBER				CU.FT. PER MIN. & HP @ SP					
PROP	TYPE	RPM	HP	1/8" SP		1/4" SP		3/8" SP	
				CFM	BHP	CFM	BHP	CFM	BHP
3-BLADE									
040A307	ATAD	1160	1/12	551	0.03				
040A312	ATAD	1160	1/12	895	0.04				
040A317	ATAD	1160	1/12	1133	0.06				
040A322	ATAD	1160	1/12	1346	0.08				
040A327	ATAD	1160	1/12	1506	0.09				
040A332	ATAD	1160	1/8	1647	0.11				
040A337	ATAD	1160	1/4	1742	0.13				
6-BLADE									
040A607	ATAD	1160	1/12	702	0.05				
040A612	ATAD	1160	1/12	1031	0.07	503	0.06		
040A617	ATAD	1160	1/8	1322	0.09				
040A622	ATAD	1160	1/8	1593	0.12	1236	0.12		
040A627	ATAD	1160	1/6	1831	0.15	1473	0.15		
040A632	ATAD	1160	1/4	2041	0.19				
040A637	ATAD	1160	1/4	2253	0.23	1791	0.22		

Size 040A ATAD – 1750 RPM

CATALOG NUMBER				CU. FT. PER MIN. & HP @ STATIC PRESSURE											
PROP	TYPE	RPM	HP	1/8" SP		1/4" SP		3/8" SP		1/2" SP		5/8" SP		3/4" SP	
				CFM	BHP	CFM	BHP	CFM	BHP	CFM	BHP	CFM	BHP	CFM	BHP
3-BLADE															
040A307	ATAD	1750	1/8	1215	0.11	936	0.11								
040A312	ATAD	1750	1/4	1648	0.14	1426	0.15	1077	0.14						
040A317	ATAD	1750	1/4	2018	0.19	1786	0.20	1462	0.20						
040A322	ATAD	1750	1/4	2347	0.25	2110	0.26	1780	0.26						
040A327	ATAD	1750	1/2	2628	0.31	2361	0.32	2011	0.32						
040A332	ATAD	1750	1/2	2907	0.40	2590	0.40	2191	0.38						
040A337	ATAD	1750	1/2	3103	0.47	2740	0.46	2324	0.44						
6-BLADE															
040A607	ATAD	1750	1/6	1268	0.17	1109	0.17	918	0.17	652	0.16				
040A612	ATAD	1750	1/4	1734	0.22	1599	0.23	1413	0.23	1104	0.23				
040A617	ATAD	1750	1/2	2163	0.28	2034	0.30	1874	0.31	1609	0.31				
040A622	ATAD	1750	1/2	2589	0.37	2446	0.39	2277	0.41	2059	0.42				
040A627	ATAD	1750	1/2	2973	0.48	2811	0.50	2623	0.51	2393	0.52				
040A632	ATAD	1750	3/4	3326	0.62	3135	0.64	2920	0.65	2661	0.64				
040A637	ATAD	1750	3/4	3668	0.78	3465	0.79	3192	0.78	2908	0.76				

Size 040A ATAD – 3500 RPM

CATALOG NUMBER				CUBIC FEET PER MINUTE AND HORSEPOWER AT STATIC PRESSURE													
PROP	TYPE	RPM	HP	1/4" SP		1/2" SP		3/4" SP		1" SP		1 1/4" SP		1 1/2" SP		2" SP	
				CFM	BHP	CFM	BHP	CFM	BHP	CFM	BHP	CFM	BHP	CFM	BHP	CFM	BHP
3-BLADE																	
040A307	ATAD	3500	1	2645	0.84	2430	0.86	2166	0.87	1872	0.85	1449	0.79				
040A312	ATAD	3500	1 1/2	3481	1.07	3296	1.10	3090	1.14	2851	1.16	2560	1.17	2154	1.13		
040A317	ATAD	3500	1 1/2	4220	1.44	4035	1.49	3824	1.53	3572	1.56	3284	1.59	2924	1.58		
040A322	ATAD	3500	2	4889	1.97	4694	2.02	4476	2.06	4219	2.10	3921	2.12	3560	2.11		
6-BLADE																	
040A607	ATAD	3500	1 1/2	2676	1.33	2537	1.35	2384	1.36	2217	1.36	2035	1.36	1837	1.35	1303	1.27
040A612	ATAD	3500	2	3585	1.68	3468	1.73	3341	1.78	3198	1.83	3033	1.86	2827	1.87	2207	1.80
040A617	ATAD	3500	2	4440	2.14												

Performance certified is for installation type D: Ducted inlet, ducted outlet.
Performance ratings do not include the effects of appurtenances (accessories).

Performance Data – Direct Drive Model ATAD

Size 050A ATAD – 1160 RPM

CATALOG NUMBER				CU. FT. PER MIN. & HP @ STATIC PRESSURE									
PROP	TYPE	RPM	HP	1/8" SP		1/4" SP		3/8" SP		1/2" SP		5/8" SP	
				CFM	BHP	CFM	BHP	CFM	BHP	CFM	BHP	CFM	BHP
3-BLADE													
050A307	ATAD	1160	1/8	1860	0.12	1300	0.11						
050A312	ATAD	1160	1/6	2354	0.15	1848	0.15						
050A317	ATAD	1160	1/4	2797	0.19	2274	0.20						
050A322	ATAD	1160	1/4	3274	0.25	2715	0.25						
050A327	ATAD	1160	1/2	3729	0.33	3136	0.32						
050A332	ATAD	1160	1/2	4064	0.39	3432	0.38						
050A337	ATAD	1160	1/2	4313	0.47	3645	0.45						
6-BLADE													
050A607	ATAD	1160	1/6	1943	0.18	1586	0.18	1030	0.17				
050A612	ATAD	1160	1/4	2510	0.23	2172	0.24	1321	0.22				
050A617	ATAD	1160	1/2	3117	0.29	2816	0.31	2328	0.32				
050A622	ATAD	1160	1/2	3721	0.38	3410	0.40	2992	0.42				
050A627	ATAD	1160	1/2	4269	0.48	3941	0.51	3458	0.52				
050A632	ATAD	1160	3/4	4796	0.62	4417	0.64	3851	0.64				
050A637	ATAD	1160	3/4	5209	0.76	4744	0.77	4118	0.74				

Size 050A ATAD – 1750 RPM

CATALOG NUMBER				CUBIC FEET PER MINUTE AND HORSEPOWER AT STATIC PRESSURE															
PROP	TYPE	RPM	HP	1/8" SP		1/4" SP		3/8" SP		1/2" SP		5/8" SP		3/4" SP		1" SP		1 1/4" SP	
				CFM	BHP	CFM	BHP	CFM	BHP	CFM	BHP	CFM	BHP	CFM	BHP	CFM	BHP	CFM	BHP
3-BLADE																			
050A307	ATAD	1750	1/2	3146	0.39	2885	0.40	2584	0.41	2220	0.40	1664	0.36						
050A312	ATAD	1750	1/2	3874	0.48	3624	0.50	3346	0.52	3011	0.53	2574	0.52	1650	0.44				
050A317	ATAD	1750	3/4	4557	0.62	4296	0.65	4009	0.66	3664	0.68	3221	0.68						
050A322	ATAD	1750	1	5289	0.84	5019	0.86	4718	0.87	4357	0.87	3856	0.86	3236	0.82				
050A327	ATAD	1750	1 1/2	5976	1.10	5707	1.11	5397	1.12	5019	1.12	4432	1.07	3876	1.03				
050A332	ATAD	1750	1 1/2	6513	1.35	6219	1.35	5881	1.35	5470	1.34	4885	1.29	4333	1.23				
050A337	ATAD	1750	1 1/2	6937	1.62	6605	1.60	6227	1.59	5780	1.56	5238	1.53	4474	1.42				
6-BLADE																			
050A607	ATAD	1750	3/4	3161	0.60	2985	0.62	2773	0.62	2534	0.62	2267	0.62	1942	0.60				
050A612	ATAD	1750	3/4	3989	0.74	3833	0.77	3652	0.79	3422	0.81	3146	0.82	2771	0.81				
050A617	ATAD	1750	1	4904	0.96	4748	0.99	4576	1.03	4376	1.06	4135	1.09	3847	1.11				
050A622	ATAD	1750	1 1/2	5829	1.24	5662	1.28	5479	1.32	5274	1.36	5032	1.39	4755	1.42				
050A627	ATAD	1750	2	6663	1.61	6491	1.65	6301	1.69	6086	1.72	5818	1.76	5496	1.78	4716	1.75		
050A632	ATAD	1750	2	7491	2.09	7293	2.12	7075	2.15	6826	2.18	6516	2.20						

Performance certified is for installation type D: Ducted inlet, ducted outlet.
 Performance ratings do not include the effects of appurtenances (accessories).

Performance Data – Direct Drive Model ATAD

Size 063A ATAD – 870 RPM

CATALOG NUMBER				CU. FT. PER MIN. & HP @ STATIC PRESSURE							
PROP	TYPE	RPM	HP	1/8" SP		1/4" SP		3/8" SP		1/2" SP	
				CFM	BHP	CFM	BHP	CFM	BHP	CFM	BHP
3-BLADE											
063A307	ATAD	870	1/6	2709	0.16	1581	0.14				
063A312	ATAD	870	1/4	3456	0.20	2508	0.20				
063A317	ATAD	870	1/4	4118	0.26	3153	0.26				
063A322	ATAD	870	1/2	4830	0.34	3781	0.34				
063A327	ATAD	870	1/2	5511	0.44	4346	0.42				
063A332	ATAD	870	1/2	6005	0.53	4793	0.50				
063A337	ATAD	870	3/4	6367	0.62	5144	0.60				
6-BLADE											
063A607	ATAD	870	1/4	2857	0.24	2225	0.24				
063A612	ATAD	870	1/2	3716	0.30	3097	0.32				
063A617	ATAD	870	1/2	4629	0.40	4085	0.43				
063A622	ATAD	870	1/2	5531	0.51	4976	0.55	4177	0.56		
063A627	ATAD	870	3/4	6352	0.65	5754	0.69	4870	0.69		
063A632	ATAD	870	1	7135	0.84	6443	0.86	5376	0.84		
063A637	ATAD	870	1	7745	1.03	6872	1.02				

Size 063A ATAD – 1160 RPM

CATALOG NUMBER				CUBIC FEET PER MINUTE AND HORSEPOWER AT STATIC PRESSURE													
PROP	TYPE	RPM	HP	1/8" SP		1/4" SP		3/8" SP		1/2" SP		5/8" SP		3/4" SP		1" SP	
				CFM	BHP	CFM	BHP	CFM	BHP	CFM	BHP	CFM	BHP	CFM	BHP	CFM	BHP
3-BLADE																	
063A307	ATAD	1160	1/2	4026	0.36	3481	0.37	2766	0.36								
063A312	ATAD	1160	1/2	4996	0.46	4487	0.48	3836	0.49	2703	0.44						
063A317	ATAD	1160	3/4	5895	0.59	5367	0.61	4693	0.63	3624	0.60						
063A322	ATAD	1160	3/4	6860	0.78	6310	0.80	5595	0.81	4542	0.77						
063A327	ATAD	1160	1	7772	1.02	7213	1.04	6464	1.03	5334	0.96						
063A332	ATAD	1160	1½	8470	1.25	7859	1.25	7053	1.23	5929	1.15						
063A337	ATAD	1160	1½	9011	1.49	8325	1.47	7463	1.44	6289	1.36						
6-BLADE																	
063A607	ATAD	1160	3/4	4092	0.56	3715	0.57	3258	0.57	2699	0.56	1889	0.52				
063A612	ATAD	1160	3/4	5201	0.70	4875	0.73	4432	0.75	3829	0.75	2357	0.67				
063A617	ATAD	1160	1	6413	0.90	6097	0.95	5711	0.99	5208	1.02	4049	0.96				
063A622	ATAD	1160	1½	7633	1.16	7296	1.22	6899	1.27	6403	1.31	5835	1.33				
063A627	ATAD	1160	1½	8736	1.50	8388	1.56	7969	1.60	7401	1.64	6753	1.65				
063A632	ATAD	1160	2	9819	1.95	9419	1.99	8934	2.02	8278	2.04	7496	2.01				
063A637	ATAD	1160	3	10678	2.41	10217	2.44	9621	2.44	8791	2.41	8029	2.33				

Size 063A ATAD – 1750 RPM

CATALOG NUMBER				CUBIC FEET PER MINUTE AND HORSEPOWER AT STATIC PRESSURE													
PROP	TYPE	RPM	HP	1/4" SP		1/2" SP		3/4" SP		1" SP		1¼" SP		1½" SP		2" SP	
				CFM	BHP	CFM	BHP	CFM	BHP	CFM	BHP	CFM	BHP	CFM	BHP	CFM	BHP
3-BLADE																	
063A307	ATAD	1750	1½	6162	1.24	5466	1.28	4618	1.27	3268	1.15						
063A312	ATAD	1750	2	7622	1.55	6968	1.63	6182	1.68	5106	1.65						
063A317	ATAD	1750	2	8982	2.00	8301	2.08	7495	2.14	6401	2.14						
063A322	ATAD	1750	3	10441	2.67	9733	2.74	8890	2.77	7668	2.74						
063A327	ATAD	1750	5	11817	3.50	11103	3.55	10221	3.56	8813	3.40	7348	3.20				
063A332	ATAD	1750	5	12878	4.27	12098	4.28	11136	4.26	9716	4.07	8247	3.84				
063A337	ATAD	1750	5	13707	5.13	12830	5.06	11768	4.98	10423	4.86						
6-BLADE																	
063A607	ATAD	1750	2	6234	1.92	5759	1.97	5175	1.98	4511	1.96	3638	1.90				
063A612	ATAD	1750	3	7900	2.37	7485	2.48	6954	2.57	6266	2.61	5210	2.52				
063A617	ATAD	1750	5	9728	3.07	9321	3.21	8846	3.35	8248	3.47	7490	3.51				
063A622	ATAD	1750	5	11572	3.97	11137	4.14	10642	4.29	10041	4.43	9338	4.53	8491	4.55		
063A627	ATAD	1750	5	13239	5.13	12789	5.30	12271	5.45								

Performance certified is for installation type D: Ducted inlet, ducted outlet.
Performance ratings do not include the effects of appurtenances (accessories).

Performance Data – Direct Drive Model ATAD

Size 071A ATAD – 870 RPM

CATALOG NUMBER				CU. FT. PER MIN. & HP @ STATIC PRESSURE									
PROP	TYPE	RPM	HP	1/8" SP		1/4" SP		3/8" SP		1/2" SP		5/8" SP	
				CFM	BHP	CFM	BHP	CFM	BHP	CFM	BHP	CFM	BHP
3-BLADE													
071A307	ATAD	870	1/4	4102	0.28	3150	0.28						
071A312	ATAD	870	1/2	5154	0.36	4277	0.38						
071A317	ATAD	870	1/2	6110	0.46	5205	0.48						
071A322	ATAD	870	3/4	7139	0.61	6190	0.62	4579	0.58				
071A327	ATAD	870	3/4	8117	0.79	7132	0.79	5496	0.73				
071A332	ATAD	870	1	8845	0.96	7773	0.95	6147	0.87				
071A337	ATAD	870	1½	9395	1.14	8214	1.11						
6-BLADE													
071A607	ATAD	870	1/2	4245	0.44	3601	0.44	2752	0.43				
071A612	ATAD	870	3/4	5452	0.54	4864	0.58	3928	0.57				
071A617	ATAD	870	3/4	6754	0.71	6222	0.75	5464	0.78				
071A622	ATAD	870	1	8054	0.91	7499	0.96	6757	1.01				
071A627	ATAD	870	1½	9234	1.17	8654	1.22	7809	1.26	6686	1.24		
071A632	ATAD	870	1½	10375	1.51	9706	1.55	8729	1.56	7385	1.50		
071A637	ATAD	870	2	11274	1.86	10479	1.87	9277	1.84				

Size 071A ATAD – 1160 RPM

CATALOG NUMBER				CUBIC FEET PER MINUTE AND HORSEPOWER AT STATIC PRESSURE															
PROP	TYPE	RPM	HP	1/8" SP		1/4" SP		3/8" SP		1/2" SP		5/8" SP		3/4" SP		1" SP		1¼" SP	
				CFM	BHP	CFM	BHP	CFM	BHP	CFM	BHP	CFM	BHP	CFM	BHP	CFM	BHP	CFM	BHP
3-BLADE																			
071A307	ATAD	1160	3/4	5908	0.65	5333	0.68	4656	0.68	3758	0.65								
071A312	ATAD	1160	1	7291	0.82	6746	0.85	6118	0.88	5319	0.89	4054	0.82						
071A317	ATAD	1160	1½	8584	1.05	8015	1.09	7371	1.13	6538	1.14	5382	1.10						
071A322	ATAD	1160	1½	9970	1.41	9381	1.44	8705	1.46	7805	1.46	6612	1.41						
071A327	ATAD	1160	2	11275	1.85	10684	1.88	9982	1.89	9017	1.85	7726	1.75						
071A332	ATAD	1160	3	12287	2.26	11642	2.27	10872	2.26	9862	2.21	8572	2.10						
071A337	ATAD	1160	3	13083	2.72	12356	2.69	11501	2.65	10467	2.60	9120	2.49						
6-BLADE																			
071A607	ATAD	1160	1	5955	1.02	5567	1.04	5087	1.05	4557	1.04	3920	1.03	2994	0.97				
071A612	ATAD	1160	1½	7531	1.25	7189	1.30	6772	1.34	6233	1.38	5594	1.37	3885	1.26				
071A617	ATAD	1160	2	9266	1.62	8927	1.69	8542	1.75	8077	1.81	7505	1.85	6720	1.84				
071A622	ATAD	1160	3	11018	2.09	10655	2.17	10250	2.25	9777	2.32	9212	2.37	8595	2.41				
071A627	ATAD	1160	3	12601	2.71	12225	2.79	11803	2.86	11298	2.93	10649	2.98	9933	3.00				
071A632	ATAD	1160	5	14164	3.52	13734	3.58	13248	3.64	12663	3.68	11912	3.70	11064	3.68				
071A637	ATAD	1160	5	15409	4.37	14918	4.41	14349	4.44	13605	4.44	12651	4.38	11828	4.29				

Size 071A ATAD – 1750 RPM

CATALOG NUMBER				CUBIC FEET PER MINUTE AND HORSEPOWER AT STATIC PRESSURE																	
PROP	TYPE	RPM	HP	1/4" SP		1/2" SP		3/4" SP		1" SP		1¼" SP		1½" SP		2" SP		2½" SP		3" SP	
				CFM	BHP	CFM	BHP	CFM	BHP	CFM	BHP	CFM	BHP	CFM	BHP	CFM	BHP	CFM	BHP	CFM	BHP
3-BLADE																					
071A307	ATAD	1750	3	9009	2.23	8269	2.30	7417	2.34	6391	2.30	4847	2.12								
071A312	ATAD	1750	3	11094	2.79	10385	2.91	9597	3.00	8651	3.05	7426	3.00	4979	2.59						
071A317	ATAD	1750	5	13048	3.60	12308	3.72	11494	3.83	10521	3.91	9272	3.90								
071A322	ATAD	1750	5	15142	4.82	14378	4.93	13525	5.01	12507	5.04	11097	4.99	9366	4.74						
071A327	ATAD	1750	7½	17110	6.32	16346	6.42	15470	6.48	14403	6.45	12758	6.20	11171	5.95						
071A332	ATAD	1750	7½	18646	7.76	17813	7.78	16855	7.78	15696	7.72	14054	7.44	12475	7.13						
071A337	ATAD	1750	10	19861	9.36	18920	9.25	17848	9.15	16586	9.03	15060	8.85	13022	8.29						
6-BLADE																					
071A607	ATAD	1750	5	9049	3.48	8551	3.55	7951	3.58	7275	3.59	6522	3.57	5609	3.49						
071A612	ATAD	1750	5	11420	4.27	10978	4.42	10465	4.56	9818	4.68	9038	4.74	7996	4.67						
071A617	ATAD	1750	7½	14037	5.53	13597	5.73	13108	5.93	12544	6.12	11865	6.29	11054	6.38						
071A622	ATAD	1750	7½	16686	7.15	16212	7.39	15694	7.62	15113	7.84	14429	8.04	13648	8.19	11352	8.13				
071A627	ATAD	1750	10	19074	9.27	18586	9.50	18048	9.73	17438	9.94	16684	10.14	15773	10.28	13597	10.12				

Performance certified is for installation type D: Ducted inlet, ducted outlet.
Performance ratings do not include the effects of appurtenances (accessories).

Performance Data – Direct Drive Model ATAD

Size 080A ATAD – 870 RPM

CATALOG NUMBER				CU. FT. PER MIN. & HP @ STATIC PRESSURE											
PROP	TYPE	RPM	HP	1/8" SP		1/4" SP		3/8" SP		1/2" SP		5/8" SP		3/4" SP	
				CFM	BHP	CFM	BHP	CFM	BHP	CFM	BHP	CFM	BHP	CFM	BHP
3-BLADE															
080A307	ATAD	870	1/2	6343	0.47	5428	0.50	3131	0.42						
080A312	ATAD	870	3/4	7890	0.61	7053	0.64	5738	0.64						
080A317	ATAD	870	1	9413	0.78	8596	0.83	7360	0.84						
080A322	ATAD	870	1½	10823	1.06	9931	1.10	8715	1.12	6507	1.05				
080A327	ATAD	870	1½	12141	1.33	11124	1.35	9766	1.34	7577	1.27				
080A332	ATAD	870	1½	13329	1.65	12201	1.64	10682	1.60	8469	1.54				
080A337	ATAD	870	2	14367	2.01	13164	1.97	11302	1.88						
6-BLADE															
080A607	ATAD	870	3/4	6333	0.77	5617	0.79	4543	0.76	3450	0.75				
080A612	ATAD	870	1	8339	0.97	7809	1.04	6957	1.06	4428	0.93				
080A617	ATAD	870	1½	10034	1.19	9527	1.27	8876	1.35	7810	1.39				
080A622	ATAD	870	2	11868	1.58	11345	1.67	10693	1.75	9754	1.81				
080A627	ATAD	870	2	13554	2.00	12951	2.09	12199	2.17	11166	2.23				
080A632	ATAD	870	3	15232	2.54	14552	2.62	13642	2.68	12400	2.71	11110	2.67		
080A637	ATAD	870	3	16915	3.26	16192	3.32	15053	3.34	13465	3.27				

Size 080A ATAD – 1160 RPM

CATALOG NUMBER				CUBIC FEET PER MINUTE AND HORSEPOWER AT STATIC PRESSURE																			
PROP	TYPE	RPM	HP	1/8" SP		1/4" SP		3/8" SP		1/2" SP		5/8" SP		3/4" SP		1" SP		1¼" SP		1½" SP			
				CFM	BHP	CFM	BHP	CFM	BHP	CFM	BHP	CFM	BHP	CFM	BHP	CFM	BHP	CFM	BHP	CFM	BHP	CFM	BHP
3-BLADE																							
080A307	ATAD	1160	1½	8940	1.09	8317	1.13	7656	1.17	6864	1.18	5643	1.13										
080A312	ATAD	1160	1½	10944	1.39	10393	1.46	9783	1.51	9061	1.53	8048	1.53	6665	1.49								
080A317	ATAD	1160	2	13011	1.79	12416	1.87	11806	1.93	11164	1.98	10248	2.01	8878	1.96								
080A322	ATAD	1160	3	14908	2.44	14289	2.52	13625	2.58	12915	2.62	12019	2.65	10686	2.65								
080A327	ATAD	1160	3	16718	3.10	16030	3.16	15279	3.19	14450	3.19	13438	3.19	12069	3.15								
080A332	ATAD	1160	5	18360	3.91	17597	3.91	16765	3.90	15842	3.88	14711	3.83	13224	3.74								
080A337	ATAD	1160	5	19699	4.76	18989	4.75	18146	4.71	16984	4.62	15583	4.50	13884	4.38								
6-BLADE																							
080A607	ATAD	1160	2	8792	1.79	8339	1.84	7820	1.87	7189	1.86	6352	1.81	5471	1.80	3944	1.75						
080A612	ATAD	1160	3	11377	2.24	11040	2.33	10656	2.42	10189	2.48	9553	2.51	8288	2.47	4950	2.20						
080A617	ATAD	1160	3	13641	2.74	13301	2.84	12928	2.95	12509	3.05	12021	3.17	11414	3.27								
080A622	ATAD	1160	5	16097	3.64	15743	3.77	15358	3.89	14931	4.00	14442	4.11	13848	4.21	12056	4.30						
080A627	ATAD	1160	5	18387	4.66	17978	4.78	17534	4.89	17043	4.99	16479	5.10	15793	5.20	14091	5.32						
080A632	ATAD	1160	7½	20660	5.94	20205	6.04	19706	6.15	19145	6.24	18467	6.33	17563	6.39	15825	6.42						
080A637	ATAD	1160	7½	22915	7.67	22445	7.76	21917	7.83	21303	7.89	20487	7.92	19051	7.86	17223	7.66						

Size 080A ATAD – 1750 RPM

CATALOG NUMBER				CUBIC FEET PER MINUTE AND HORSEPOWER AT STATIC PRESSURE																			
PROP	TYPE	RPM	HP	1/4" SP		1/2" SP		3/4" SP		1" SP		1¼" SP		1½" SP		2" SP		2½" SP		3" SP			
				CFM	BHP	CFM	BHP	CFM	BHP	CFM	BHP	CFM	BHP	CFM	BHP	CFM	BHP	CFM	BHP	CFM	BHP	CFM	BHP
3-BLADE																							
080A307	ATAD	1750	5	13598	3.72	12777	3.84	11929	3.97	10967	4.05	9764	4.03	6712	3.51								
080A312	ATAD	1750	5	16605	4.73	15888	4.97	15105	5.14	14232	5.22	13130	5.26	11656	5.23								
080A317	ATAD	1750	7½	19734	6.12	18952	6.36	18143	6.57	17329	6.74	16388	6.86	14930	6.88								
080A322	ATAD	1750	10	22600	8.35	21789	8.58	20925	8.78	20019	8.93	19010	9.03	17646	9.11	13393	8.62						
080A327	ATAD	1750	10	25341	10.61	24442	10.80	23474	10.93	22427	10.97	21248	10.96	19763	10.93	15448	10.34						
6-BLADE																							
080A607	ATAD	1750	7½	13342	6.11	12754	6.28	12097	6.39	11338	6.41	10370	6.32	9221	6.21	7031	6.14						
080A612	ATAD	1750	10	17221	7.64	16784	7.93	16297	8.19	15735	8.42	15034	8.58	14076	8.64	9063	7.60						
080A617	ATAD	1750	10	20638	9.36	20195	9.68	19715	10.00	19188	10.31	18597	10.63	17907	10.97								

Performance certified is for installation type D: Ducted inlet, ducted outlet.
Performance ratings do not include the effects of appurtenances (accessories).

Performance Data – Direct Drive Model ATAD

Size 090A ATAD – 870 RPM

CATALOG NUMBER				CU. FT. PER MIN. & HP @ STATIC PRESSURE													
PROP	TYPE	RPM	HP	1/8" SP		1/4" SP		3/8" SP		1/2" SP		5/8" SP		3/4" SP		1" SP	
				CFM	BHP	CFM	BHP	CFM	BHP	CFM	BHP	CFM	BHP	CFM	BHP	CFM	BHP
3-BLADE																	
090A307	ATAD	870	1	9254	0.84	8293	0.88	7086	0.89								
090A312	ATAD	870	1½	11423	1.08	10546	1.14	9444	1.16	7726	1.15						
090A317	ATAD	870	1½	13602	1.38	12693	1.46	11716	1.51	10026	1.51						
090A322	ATAD	870	2	15614	1.87	14645	1.94	13571	1.99	11947	2.01	9441	1.90				
090A327	ATAD	870	3	17514	2.36	16426	2.41	15175	2.42	13434	2.40	10895	2.28				
090A332	ATAD	870	3	19231	2.96	18025	2.96	16632	2.93	14692	2.86	12224	2.77				
090A337	ATAD	870	5	20685	3.60	19508	3.58	17763	3.48	15519	3.35						
6-BLADE																	
090A607	ATAD	870	1½	9174	1.37	8438	1.41	7473	1.40	6169	1.37	4959	1.35				
090A612	ATAD	870	2	11976	1.72	11430	1.82	10722	1.89	9527	1.90	6390	1.67				
090A617	ATAD	870	3	14384	2.11	13846	2.22	13215	2.33	12416	2.45	11190	2.50				
090A622	ATAD	870	3	16994	2.80	16436	2.92	15794	3.05	14999	3.16	13920	3.25				
090A627	ATAD	870	5	19409	3.56	18765	3.68	18027	3.80	17108	3.91	15924	3.99	14474	4.03		
090A632	ATAD	870	5	21811	4.53	21090	4.64	20246	4.74	19087	4.82	17673	4.86	16429	4.84		
090A637	ATAD	870	7½	24207	5.83	23452	5.92	22526	5.98	20895	5.98	19185	5.88	17858	5.74		

Size 090A ATAD – 1160 RPM

CATALOG NUMBER				CUBIC FEET PER MINUTE AND HORSEPOWER AT STATIC PRESSURE																	
PROP	TYPE	RPM	HP	1/8" SP		1/4" SP		3/8" SP		1/2" SP		3/4" SP		1" SP		1¼" SP		1½" SP		2" SP	
				CFM	BHP	CFM	BHP	CFM	BHP	CFM	BHP	CFM	BHP	CFM	BHP	CFM	BHP	CFM	BHP	CFM	BHP
3-BLADE																					
090A307	ATAD	1160	2	12874	1.94	12182	1.99	11473	2.06	10699	2.10	8564	2.07								
090A312	ATAD	1160	3	15694	2.46	15094	2.57	14444	2.66	13737	2.72	11831	2.74								
090A317	ATAD	1160	5	18647	3.18	17988	3.30	17304	3.40	16620	3.49	14954	3.60	11832	3.46						
090A322	ATAD	1160	5	21347	4.35	20665	4.46	19944	4.56	19188	4.64	17438	4.74	14438	4.70						
090A327	ATAD	1160	7½	23934	5.53	23180	5.62	22374	5.69	21511	5.73	19485	5.72	16368	5.60						
090A332	ATAD	1160	7½	26286	7.01	25451	7.01	24558	7.01	23600	7.00	21343	6.91	18069	6.67						
090A337	ATAD	1160	10	28168	8.55	27403	8.54	26544	8.50	25535	8.44	22643	8.14	18821	7.82						
6-BLADE																					
090A607	ATAD	1160	3	12611	3.18	12119	3.27	11579	3.33	10970	3.35	9323	3.27	7378	3.23	5690	3.15				
090A612	ATAD	1160	5	16248	3.98	15884	4.11	15483	4.24	15032	4.36	13825	4.50	10452	4.19	7145	3.94				
090A617	ATAD	1160	7½	19466	4.87	19094	5.02	18696	5.17	18264	5.32	17256	5.63	15859	5.91						
090A622	ATAD	1160	7½	22958	6.49	22570	6.67	22157	6.84	21713	7.01	20694	7.33	19340	7.61	17289	7.73				
090A627	ATAD	1160	10	26226	8.32	25777	8.48	25300	8.64	24788	8.80	23616	9.10	22060	9.38	20127	9.55				
090A632	ATAD	1160	15	29465	10.61	28968	10.76	28435	10.91	27857	11.05	26493	11.31	24473	11.49	22570	11.52				
090A637	ATAD	1160	15	32672	13.74	32159	13.86	31603	13.97	30988	14.06	29447	14.20	26477	14.05	24563	13.77				

Size 090A ATAD – 1750 RPM

CATALOG NUMBER				CUBIC FEET PER MINUTE AND HORSEPOWER AT STATIC PRESSURE																	
PROP	TYPE	RPM	HP	1/4" SP		1/2" SP		3/4" SP		1" SP		1¼" SP		1½" SP		2" SP		2½" SP		3" SP	
				CFM	BHP	CFM	BHP	CFM	BHP	CFM	BHP	CFM	BHP	CFM	BHP	CFM	BHP	CFM	BHP	CFM	BHP
3-BLADE																					
090A307	ATAD	1750	7½	19546	6.62	18635	6.80	17701	6.98	16728	7.16	15636	7.26	14356	7.26						
090A312	ATAD	1750	10	23782	8.39	22997	8.75	22157	9.05	21256	9.25	20266	9.36	19089	9.43	15735	9.34				
090A317	ATAD	1750	15	28250	10.88	27381	11.24	26485	11.56	25574	11.84	24659	12.07	23646	12.26	20352	12.27				
090A322	ATAD	1750	15	32325	14.89	31430	15.23	30491	15.54	29504	15.80	28484	16.00	27380	16.16	24224	16.37	19343	15.56		
090A327	ATAD	1750	20	36241	18.96	35252	19.24	34206	19.47	33094	19.63	31912	19.69	30619	19.67	27217	19.57	22215	18.62		
090A332	ATAD	1750	25	39803	24.05	38708	24.08	37550	24.09	36317	24.06	35003	24.00	33562	23.89	29765	23.28	24978	22.59		
090A337	ATAD	1750	30	42627	29.35	41632	29.32	40536	29.25	39302	29.11	37798	28.83	35874	28.35	31457	27.28				
6-BLADE																					
090A607	ATAD	1750	15	19110	10.88	18469	11.15	17775	11.37	17010	11.49	16149	11.51	15115	11.41	12533	11.12	10103	11.02	7887	10.63
090A612	ATAD	1750	15	24576	13.59	24100	14.01	23585	14.41	23019	14.77	22382	15.09	21625	15.34	19342	15.48	13080	13.63		
090A617	ATAD	1750	20	29433	16.67	28945	17.13	28428	17.58	27877	18.03	27281	18.48	26630	18.93	25059	19.88	22706	20.36		
090A622	ATAD	1750	25	34704	22.22	34195	22.75	33658	23.27	33088	23.78	32478	24.28	31817	24.76	30254	25.68	28144	26.39		
090A627	ATAD	1750	30	39644	28.49	39056	28.99	38436	29.47	37778	29.95	37075	30.42	36317	30.88	34508	31.76	32176	32.47	29377	32.80

Performance certified is for installation type D: Ducted inlet, ducted outlet.
Performance ratings do not include the effects of appurtenances (accessories).

Performance Data – Direct Drive Model ATAD

Size 100A ATAD – 870 RPM

CATALOG NUMBER				CUBIC FEET PER MINUTE AND HORSEPOWER AT STATIC PRESSURE																	
				1/8" SP		1/4" SP		3/8" SP		1/2" SP		5/8" SP		3/4" SP		1" SP		1 1/4" SP		1 1/2" SP	
PROP	TYPE	RPM	HP	CFM	BHP	CFM	BHP	CFM	BHP	CFM	BHP	CFM	BHP	CFM	BHP	CFM	BHP	CFM	BHP	CFM	BHP
3-BLADE																					
100A307	ATAD	870	1 1/2	12980	1.41	11936	1.47	10772	1.52	9221	1.50										
100A312	ATAD	870	2	15934	1.80	14996	1.91	13933	1.96	12525	1.97	10510	1.95								
100A317	ATAD	870	3	18952	2.32	17951	2.43	16932	2.52	15722	2.58	13681	2.56								
100A322	ATAD	870	5	21730	3.16	20681	3.27	19556	3.34	18271	3.40	16321	3.42	13602	3.28						
100A327	ATAD	870	5	24369	4.01	23202	4.08	21913	4.12	20418	4.11	18366	4.09	15563	3.92						
100A332	ATAD	870	5	26761	5.04	25468	5.04	24036	5.02	22371	4.98	20088	4.85	17471	4.74						
100A337	ATAD	870	7 1/2	28739	6.14	27516	6.11	25970	6.04	23779	5.87	21250	5.69								
6-BLADE																					
100A607	ATAD	870	3	12800	2.31	12025	2.39	11108	2.41	9878	2.36	8415	2.33	7057	2.31						
100A612	ATAD	870	3	16610	2.90	16035	3.04	15357	3.15	14464	3.23	12990	3.23	9219	2.86						
100A617	ATAD	870	5	19927	3.55	19350	3.70	18705	3.86	17957	4.01	17033	4.18	15737	4.26						
100A622	ATAD	870	5	23524	4.72	22925	4.90	22261	5.07	21506	5.23	20590	5.39	19414	5.51						
100A627	ATAD	870	7 1/2	26870	6.03	26178	6.19	25413	6.36	24545	6.51	23484	6.66	22177	6.78						
100A632	ATAD	870	7 1/2	30192	7.67	29421	7.83	28556	7.97	27551	8.10	26188	8.22	24585	8.27						
100A637	ATAD	870	10	33496	9.91	32694	10.02	31771	10.12	30643	10.19	28619	10.17	26659	10.03						

Size 100A ATAD – 1160 RPM

CATALOG NUMBER				CUBIC FEET PER MINUTE AND HORSEPOWER AT STATIC PRESSURE																	
				1/4" SP		1/2" SP		3/4" SP		1" SP		1 1/4" SP		1 1/2" SP		2" SP		2 1/2" SP			
PROP	TYPE	RPM	HP	CFM	BHP	CFM	BHP	CFM	BHP	CFM	BHP	CFM	BHP	CFM	BHP	CFM	BHP	CFM	BHP	CFM	BHP
3-BLADE																					
100A307	ATAD	1160	5	17135	3.36	15553	3.52	13691	3.61	10518	3.38										
100A312	ATAD	1160	5	21096	4.31	19660	4.56	17963	4.66	15462	4.66										
100A317	ATAD	1160	7 1/2	25107	5.54	23594	5.83	22035	6.04	19740	6.13	16055	5.87								
100A322	ATAD	1160	7 1/2	28805	7.53	27207	7.80	25476	7.98	23226	8.10	19655	7.97								
100A327	ATAD	1160	10	32306	9.52	30522	9.71	28516	9.76	25983	9.73	22302	9.50								
100A332	ATAD	1160	15	35475	11.94	33498	11.94	31267	11.88	28436	11.68	24672	11.34								
100A337	ATAD	1160	15	38129	14.54	36231	14.46	33612	14.18	30106	13.71	25626	13.31								
6-BLADE																					
100A607	ATAD	1160	7 1/2	16945	5.51	15749	5.68	14275	5.70	12212	5.53	10052	5.50	8177	5.39						
100A612	ATAD	1160	7 1/2	22057	6.92	21170	7.27	20077	7.55	18487	7.68	13974	7.04	10296	6.74						
100A617	ATAD	1160	10	26478	8.46	25595	8.87	24586	9.28	23366	9.71	21724	10.07	11525	8.12						
100A622	ATAD	1160	15	31270	11.24	30354	11.71	29321	12.17	28098	12.59	26523	12.97	24353	13.17						
100A627	ATAD	1160	15	35716	14.34	34659	14.78	33469	15.21	32060	15.61	30257	15.98	28133	16.23						
100A632	ATAD	1160	20	40133	18.23	38953	18.64	37601	19.02	35903	19.36	33556	19.57	31434	19.62						
100A637	ATAD	1160	25	44535	23.52	43302	23.82	41840	24.07	39773	24.20	36306	23.90	34197	23.53						

Size 100A ATAD – 1750 RPM

CATALOG NUMBER				CUBIC FEET PER MINUTE AND HORSEPOWER AT STATIC PRESSURE																	
				1/4" SP		1/2" SP		3/4" SP		1" SP		1 1/4" SP		1 1/2" SP		2" SP		2 1/2" SP		3" SP	
PROP	TYPE	RPM	HP	CFM	BHP	CFM	BHP	CFM	BHP	CFM	BHP	CFM	BHP	CFM	BHP	CFM	BHP	CFM	BHP	CFM	BHP
3-BLADE																					
100A307	ATAD	1750	15	27135	11.22	26132	11.46	25101	11.70	24057	11.96	22963	12.20	21756	12.34	18731	12.25				
100A312	ATAD	1750	15	32928	14.16	32071	14.68	31168	15.13	30211	15.51	29199	15.77	28107	15.92	25352	16.07	21417	15.89		
100A317	ATAD	1750	20	39102	18.40	38145	18.91	37163	19.37	36156	19.79	35144	20.17	34129	20.50	31763	20.99	27781	20.87		
100A322	ATAD	1750	25	44716	25.24	43733	25.72	42712	26.17	41651	26.57	40547	26.92	39416	27.20	36887	27.62	33100	27.87	27802	26.86
100A327	ATAD	1750	30	50128	32.19	49044	32.59	47913	32.94	46727	33.22	45480	33.43	44171	33.52	41224	33.46	37217	33.30	31741	32.07
100A332	ATAD	1750	40	55058	40.94	53858	40.99	52605	41.01	51291	41.01	49907	40.96	48452	40.88	45170	40.54	40702	39.58	35557	38.69

Performance certified is for installation type D: Ducted inlet, ducted outlet.
Performance ratings do not include the effects of appurtenances (accessories).

Performance Data – Direct Drive Model ATAD

Size 112A ATAD – 870 RPM

CATALOG NUMBER				CUBIC FEET PER MINUTE AND HORSEPOWER AT STATIC PRESSURE																	
PROP	TYPE	RPM	HP	1/8" SP		1/4" SP		3/8" SP		1/2" SP		5/8" SP		3/4" SP		1" SP		1 1/4" SP		1 1/2" SP	
				CFM	BHP	CFM	BHP	CFM	BHP	CFM	BHP	CFM	BHP	CFM	BHP	CFM	BHP	CFM	BHP	CFM	BHP
3-BLADE																					
112A307	ATAD	870	3	18469	2.45	17313	2.53	16112	2.62	14732	2.67	12935	2.63								
112A312	ATAD	870	5	22568	3.12	21555	3.28	20445	3.39	19192	3.44	17561	3.46	15397	3.43						
112A317	ATAD	870	5	26823	4.03	25720	4.20	24581	4.33	23428	4.45	22037	4.53	19821	4.51						
112A322	ATAD	870	7 1/2	30722	5.50	29577	5.66	28356	5.79	27072	5.89	25608	5.95	23538	6.00						
112A327	ATAD	870	7 1/2	34449	6.99	33180	7.11	31808	7.20	30319	7.22	28617	7.21	26410	7.19	20151	6.72				
112A332	ATAD	870	10	37833	8.83	36427	8.84	24906	8.83	33250	8.80	31355	8.73	28884	8.57						
112A337	ATAD	870	10	40571	10.77	39271	10.74	37771	10.69	35845	10.54	33331	10.30	30546	10.04						
6-BLADE																					
112A607	ATAD	870	5	18132	4.03	17301	4.14	16366	4.21	15276	4.22	13851	4.14	12221	4.08	9209	4.03				
112A612	ATAD	870	7 1/2	23418	5.04	22801	5.23	22108	5.41	21301	5.56	20271	5.66	18806	5.69	11733	5.00				
112A617	ATAD	870	7 1/2	28068	6.17	27442	6.39	26762	6.60	26012	6.82	25162	7.04	24158	7.27	20902	7.41				
112A622	ATAD	870	10	33114	8.21	32461	8.46	31758	8.71	30990	8.95	30134	9.18	29134	9.40	26418	9.72				
112A627	ATAD	870	15	37826	10.51	37072	10.75	36260	10.98	35376	11.20	34392	11.42	33234	11.63	30294	11.96				
112A632	ATAD	870	15	42500	13.40	41662	13.62	40752	13.83	39747	14.03	38604	14.21	37134	14.38	33688	14.51				
112A637	ATAD	870	20	47134	17.33	46268	17.50	45312	17.65	44227	17.78	42938	17.88	40857	17.88	36604	17.51				

Size 112A ATAD – 1160 RPM

CATALOG NUMBER				CUBIC FEET PER MINUTE AND HORSEPOWER AT STATIC PRESSURE																	
PROP	TYPE	RPM	HP	1/4" SP		1/2" SP		3/4" SP		1" SP		1 1/4" SP		1 1/2" SP		2" SP		2 1/2" SP		3" SP	
				CFM	BHP	CFM	BHP	CFM	BHP	CFM	BHP	CFM	BHP	CFM	BHP	CFM	BHP	CFM	BHP	CFM	BHP
3-BLADE																					
112A307	ATAD	1160	7 1/2	24437	5.83	22694	6.06	20828	6.27	18570	6.32	14793	5.94								
112A312	ATAD	1160	7 1/2	29928	7.45	28382	7.86	26665	8.09	24600	8.20	21686	8.17	17421	7.91						
112A317	ATAD	1160	10	35583	9.61	33916	10.03	32209	10.38	30389	10.65	27680	10.75	23735	10.46						
112A322	ATAD	1160	15	40777	13.10	39039	13.50	37179	13.82	35171	14.04	32562	14.20	28710	14.12						
112A327	ATAD	1160	20	45727	16.61	43796	16.92	41687	17.10	39342	17.11	36425	17.07	32474	16.84						
112A332	ATAD	1160	20	50217	20.93	48078	20.95	45738	20.91	43127	20.79	39865	20.49	35658	19.98						
112A337	ATAD	1160	25	53889	25.52	51891	25.44	49502	25.24	46166	24.71	42207	24.05	37348	23.41						
6-BLADE																					
112A607	ATAD	1160	10	24044	9.58	22771	9.88	21306	10.01	19498	9.95	17126	9.70	14674	9.65	10433	9.30				
112A612	ATAD	1160	15	31125	11.99	30181	12.51	29096	12.97	27764	13.32	25915	13.47	21929	13.07	13098	11.73				
112A617	ATAD	1160	20	37323	14.69	36370	15.26	35320	15.84	34137	16.41	32744	17.03	30988	17.58						
112A622	ATAD	1160	25	44046	19.54	43054	20.21	41972	20.86	40767	21.49	39373	22.08	37667	22.63	32160	22.94				
112A627	ATAD	1160	30	50313	24.98	49166	25.61	47917	26.22	46532	26.81	44924	27.38	42958	27.91	38076	28.54				
112A632	ATAD	1160	40	56531	31.82	55256	32.40	53851	32.96	52265	33.48	50313	33.94	47721	34.28	42911	34.37				
112A637	ATAD	1160	40	62706	41.13	61385	41.57	59897	41.96	58155	42.28	55742	42.44	51679	42.05	46699	40.90				

Size 112A ATAD – 1750 RPM

CATALOG NUMBER				CU. FT. PER MIN. AND HORSEPOWER AT STATIC PRESSURE																	
PROP	TYPE	RPM	HP	1/4" SP		1/2" SP		3/4" SP		1" SP		1 1/4" SP		1 1/2" SP		2" SP		2 1/2" SP			
				CFM	BHP	CFM	BHP	CFM	BHP	CFM	BHP	CFM	BHP	CFM	BHP	CFM	BHP	CFM	BHP	CFM	BHP
3-BLADE																					
112A307	ATAD	1750	20	38291	19.59	37177	19.93	36039	20.26	34879	20.61	33710	20.97	32497	21.31	29771	21.70	26274	21.49		
112A312	ATAD	1750	30	46362	24.64	45417	25.39	44433	26.07	43406	26.68	42329	27.20	41204	27.58	38730	28.00	35544	28.18		
112A317	ATAD	1750	40	55042	32.09	53979	32.81	52894	33.49	51788	34.12	50657	34.71	49523	35.25	47237	36.15	44521	36.81		
112A322	ATAD	1750	50	62912	44.10	61823	44.78	60703	45.43	59548	46.04	58356	46.59	57124	47.10	54578	47.87	51699	48.43		

CATALOG NUMBER				CU. FT. PER MIN. AND HP AT STATIC PRESSURE							
PROP	TYPE	RPM	HP	3" SP		3 1/2" SP		4" SP		4 1/2" SP	
				CFM	BHP	CFM	BHP	CFM	BHP	CFM	BHP
3-BLADE											
112A307	ATAD	1750	20	16420	17.99						
112A312	ATAD	1750	30	31304	27.98						
112A317	ATAD	1750	40	40220	36.77	34740	35.60				
112A322	ATAD	1750	50	47690	48.86	42300	48.24				

Performance certified is for installation type D: Ducted inlet, ducted outlet.
Performance ratings do not include the effects of appurtenances (accessories).

Performance Data – Direct Drive Model ATAD

Size 125A ATAD – 870 RPM

CATALOG NUMBER				CUBIC FEET PER MINUTE AND HORSEPOWER AT STATIC PRESSURE																	
PROP	TYPE	RPM	HP	1/8" SP		1/4" SP		3/8" SP		1/2" SP		3/4" SP		1" SP		1 1/4" SP		1 1/2" SP		2" SP	
				CFM	BHP	CFM	BHP	CFM	BHP	CFM	BHP	CFM	BHP	CFM	BHP	CFM	BHP	CFM	BHP	CFM	BHP
3-BLADE																					
125A307	ATAD	870	5	26072	4.23	24795	4.35	23486	4.48	22104	4.59	18618	4.62								
125A312	ATAD	870	7 1/2	31741	5.37	30639	5.61	29454	5.80	28178	5.93	24998	6.03	19941	5.93						
125A317	ATAD	870	7 1/2	37708	6.96	36491	7.20	35233	7.41	33961	7.59	31172	7.86	26182	7.79						
125A322	ATAD	870	10	43154	9.52	41898	9.75	40577	9.95	39190	10.12	36148	10.34	31333	10.44						
125A327	ATAD	870	15	48383	12.12	46995	12.31	45522	12.45	43952	12.55	40407	12.56	35317	12.46	28042	11.69				
125A332	ATAD	870	15	53139	15.36	51601	15.38	49970	15.38	48228	15.36	44282	15.23	38646	14.77						
125A337	ATAD	870	20	56920	18.75	55519	18.73	53967	18.67	52202	18.57	47180	18.02	40705	17.29						
6-BLADE																					
125A607	ATAD	870	7 1/2	25506	6.96	24605	7.14	23623	7.28	22536	7.35	19750	7.25	16101	7.10	12822	7.01				
125A612	ATAD	870	10	32821	8.70	32153	8.97	31425	9.24	30620	9.48	28584	9.83	24738	9.82	16331	8.70				
125A617	ATAD	870	15	39313	10.66	38628	10.97	37900	11.27	37120	11.57	35337	12.18	33028	12.80	29102	12.90				
125A622	ATAD	870	20	46357	14.21	45643	14.56	44887	14.91	44082	15.25	42270	15.90	39984	16.50	36819	16.92				
125A627	ATAD	870	20	52956	18.22	52130	18.55	51257	18.87	50328	19.19	48246	19.81	45601	20.39	42226	20.82				
125A632	ATAD	870	25	59496	23.24	58581	23.55	57607	23.86	56562	24.15	54173	24.68	50791	25.12	46961	25.26	43209	25.06		
125A637	ATAD	870	30	65964	30.11	65023	30.35	64009	30.57	62903	30.78	60267	31.10	55302	31.01	51029	30.47				

Size 125A ATAD – 1160 RPM

CATALOG NUMBER				CUBIC FEET PER MINUTE AND HORSEPOWER AT STATIC PRESSURE																	
PROP	TYPE	RPM	HP	1/4" SP		1/2" SP		3/4" SP		1" SP		1 1/4" SP		1 1/2" SP		2" SP		2 1/2" SP		3" SP	
				CFM	BHP	CFM	BHP	CFM	BHP	CFM	BHP	CFM	BHP	CFM	BHP	CFM	BHP	CFM	BHP	CFM	BHP
3-BLADE																					
125A307	ATAD	1160	10	34553	10.07	32625	10.39	30644	10.72	28458	10.96	25879	11.01	22103	10.60						
125A312	ATAD	1160	15	42143	12.81	40468	13.42	38650	13.89	36657	14.14	34291	14.27	31111	14.25						
125A317	ATAD	1160	20	50077	16.57	48241	17.19	46336	17.73	44432	18.18	42367	18.54	39525	18.72	30307	17.74				
125A322	ATAD	1160	25	57334	22.65	55432	23.24	53417	23.75	51306	24.15	49036	24.44	46253	24.67	37389	24.16				
125A327	ATAD	1160	30	64284	28.79	62180	29.27	59927	29.62	57506	29.80	54850	29.79	51698	29.73	42517	28.81				
125A332	ATAD	1160	40	70601	36.43	68271	36.47	65773	36.46	63085	36.37	60126	36.20	56606	35.82	47296	34.54				
125A337	ATAD	1160	50	75668	44.43	73529	44.37	71114	44.19	68224	43.81	64358	43.02	59987	42.11	48526	40.46				
6-BLADE																					
125A607	ATAD	1160	20	33863	16.56	32491	17.01	30973	17.33	29252	17.43	27178	17.32	24536	16.92	19182	16.77	14518	16.19		
125A612	ATAD	1160	25	43654	20.70	42636	21.43	41512	22.11	40237	22.72	38710	23.19	36725	23.43	25857	21.05	18228	20.42		
125A617	ATAD	1160	30	52306	25.37	51268	26.17	50153	26.98	48941	27.78	47600	28.58	46073	29.43	41960	30.81				
125A622	ATAD	1160	40	61693	33.79	60611	34.73	59455	35.65	58209	36.54	56847	37.41	55318	38.25	51389	39.71	44758	39.32		
125A627	ATAD	1160	50	70474	43.28	69222	44.15	67888	45.02	66452	45.86	64886	46.68	63124	47.48	58642	48.91	53057	49.69		

Size 125A ATAD – 1750 RPM

CATALOG NUMBER				CUBIC FEET PER MINUTE AND HORSEPOWER AT STATIC PRESSURE																					
PROP	TYPE	RPM	HP	1/4" SP		1/2" SP		3/4" SP		1" SP		1 1/4" SP		1 1/2" SP		2" SP		2 1/2" SP		3" SP		3 1/2" SP		4" SP	
				CFM	BHP	CFM	BHP	CFM	BHP	CFM	BHP	CFM	BHP	CFM	BHP	CFM	BHP	CFM	BHP	CFM	BHP	CFM	BHP	CFM	BHP
3-BLADE																									
125A307	ATAD	1750	40	53708	33.98	52472	34.45	51214	34.93	49934	35.40	48637	35.88	47333	36.39	44597	37.31	41499	37.79	37758	37.64	32104	35.95		
125A312	ATAD	1750	50	64916	42.63	63872	43.70	62795	44.69	61682	45.61	60529	46.45	59332	47.19	56802	48.21	53995	48.75	50560	49.06	46120	48.88	40708	48.34

Performance certified is for installation type D: Ducted inlet, ducted outlet.
Performance ratings do not include the effects of appurtenances (accessories).

Performance Data – Belt Driven Model ATAB

Catalog Numbering System

To identify a specific fan for ordering or engineering specifications, it is necessary to show the complete information listed in the tables below under “catalog number.” All performance data is available in curve form upon request.

The model ATAB fans shown herein have been tested in accordance with ASHRAE 51-85 and AMCA 210-85 Test Code and are guaranteed by the manufacturer to deliver rated performance.

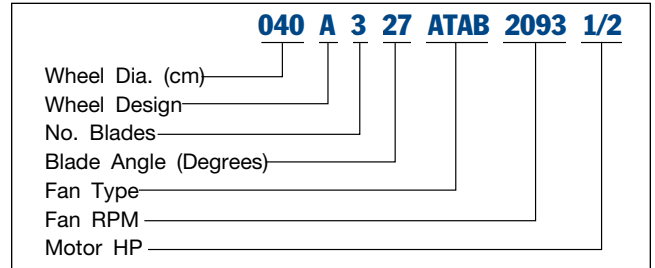

Size 040A327 ATAB

CATALOG NUMBER				CUBIC FEET PER MINUTE AND HORSEPOWER AT STATIC PRESSURE																
				1/4" SP		1/2" SP		3/4" SP		1" SP		1 1/4" SP		1 1/2" SP		2" SP		2 1/2" SP		
PROP	TYPE	RPM	HP	CFM	BHP	CFM	BHP	CFM	BHP	CFM	BHP	CFM	BHP	CFM	BHP	CFM	BHP	CFM	BHP	
040A327	ATAB	2093	1/2	2857	0.55	2344	0.54													
040A327	ATAB	2396	3/4	3383	0.82	2990	0.82	2459	0.80											
040A327	ATAB	2637	1	3790	1.09	3453	1.10	3038	1.09	2465	1.03									
040A327	ATAB	3018	1 1/2	4419	1.63	4143	1.64	3826	1.65	3448	1.63	2969	1.57							
040A327	ATAB	3322	2	4914	2.17	4671	2.18	4401	2.20	4095	2.19	3735	2.16	3297	2.10					
040A327	ATAB	3803	3	5688	3.24	5482	3.27	5261	3.28	5021	3.30	4756	3.30	4459	3.27	3714	3.14			

Size 050A327 ATAB

CATALOG NUMBER				CUBIC FEET PER MINUTE AND HORSEPOWER AT STATIC PRESSURE																
				1/4" SP		1/2" SP		3/4" SP		1" SP		1 1/4" SP		1 1/2" SP		2" SP		2 1/2" SP		
PROP	TYPE	RPM	HP	CFM	BHP	CFM	BHP	CFM	BHP	CFM	BHP	CFM	BHP	CFM	BHP	CFM	BHP	CFM	BHP	
050A327	ATAB	1380	1/2	4040	0.55															
050A327	ATAB	1579	3/4	4864	0.82	3868	0.78													
050A327	ATAB	1738	1	5481	1.09	4727	1.08	3569	0.98											
050A327	ATAB	1990	1 1/2	6426	1.63	5880	1.65	5057	1.59											
050A327	ATAB	2190	2	7159	2.17	6708	2.20	6085	2.18	5226	2.07									
050A327	ATAB	2507	3	8303	3.24	7938	3.28	7498	3.30	6923	3.26	6175	3.15	5409	3.01					
050A327	ATAB	2973	5	9960	5.37	9671	5.43	9351	5.48	8983	5.50	8532	5.48	8002	5.41	6707	5.10			

Size 063A327 ATAB

CATALOG NUMBER				CUBIC FEET PER MINUTE AND HORSEPOWER AT STATIC PRESSURE																	
				1/4" SP		1/2" SP		3/4" SP		1" SP		1 1/4" SP		1 1/2" SP		2" SP		2 1/2" SP		3" SP	
PROP	TYPE	RPM	HP	CFM	BHP	CFM	BHP	CFM	BHP	CFM	BHP	CFM	BHP	CFM	BHP	CFM	BHP	CFM	BHP	CFM	BHP
063A327	ATAB	1075	3/4	6233	0.82																
063A327	ATAB	1183	1	7155	1.10	5357	1.02														
063A327	ATAB	1354	1 1/2	8505	1.64	7247	1.62														
063A327	ATAB	1490	2	9534	2.18	8542	2.19	7014	2.07												
063A327	ATAB	1706	3	11128	3.25	10387	3.30	9351	3.26	7940	3.09										
063A327	ATAB	2023	5	13415	5.39	12851	5.47	12177	5.50	11302	5.45	10179	5.29	8985	5.08						
063A327	ATAB	2315	7 1/2	15492	8.05	15023	8.15	14499	8.21	13887	8.24	13132	8.19	12238	8.06	10128	7.57				
063A327	ATAB	2548	10	17137	10.71	16721	10.82	16269	10.91	15769	10.97	15188	10.98	14497	10.93	12751	10.54	10807	9.98		

Size 071A327 ATAB

CATALOG NUMBER				CUBIC FEET PER MINUTE AND HORSEPOWER AT STATIC PRESSURE																
				1/4" SP		1/2" SP		3/4" SP		1" SP		1 1/4" SP		1 1/2" SP		2" SP		2 1/2" SP		
PROP	TYPE	RPM	HP	CFM	BHP	CFM	BHP	CFM	BHP	CFM	BHP	CFM	BHP	CFM	BHP	CFM	BHP	CFM	BHP	
071A327	ATAB	881	3/4	6952	0.82															
071A327	ATAB	969	1	8107	1.10															
071A327	ATAB	1110	1 1/2	9781	1.65	7762	1.57													
071A327	ATAB	1221	2	11015	2.19	9485	2.17	7100	1.96											
071A327	ATAB	1398	3	12915	3.27	11808	3.30	10135	3.18											
071A327	ATAB	1657	5	15618	5.40	14810	5.48	13771	5.48	12380	5.35	10713	5.10							
071A327	ATAB	1897	7 1/2	18077	8.07	17414	8.17	16650	8.23	15693	8.22	14512	8.09	13028	7.79					
071A327	ATAB	2088	10	20016	10.73	19432	10.86	18784	10.95	18037	10.99	17120	10.94	16043	10.80	13423	10.18			

Power ratings (BHP) do not include transmission losses.
 Performance certified is for installation type D: Ducted inlet, ducted outlet.
 Performance ratings do not include the effects of appurtenances (accessories).

Performance Data – Belt Driven Model ATAB

Size 080A327 ATAB

CATALOG NUMBER				CUBIC FEET PER MINUTE AND HORSEPOWER AT STATIC PRESSURE																		
PROP	TYPE	RPM	HP	1/4" SP		1/2" SP		3/4" SP		1" SP		1 1/4" SP		1 1/2" SP		2" SP		2 1/2" SP		3" SP		
				CFM	BHP	CFM	BHP	CFM	BHP	CFM	BHP	CFM	BHP	CFM	BHP	CFM	BHP	CFM	BHP	CFM	BHP	CFM
080A327	ATAB	815	1	9859	1.10																	
080A327	ATAB	933	1 1/2	11925	1.64	8916	1.60															
080A327	ATAB	1027	2	13487	2.19	11365	2.19															
080A327	ATAB	1175	3	15869	3.26	14352	3.29	11771	3.21													
080A327	ATAB	1393	5	19273	5.39	18094	5.46	16731	5.49	14539	5.40											
080A327	ATAB	1595	7 1/2	22364	8.06	21381	8.16	20298	8.22	19066	8.24	17246	8.15	14860	7.94							
080A327	ATAB	1756	10	24800	10.73	23930	10.84	22986	10.93	21966	10.99	20795	11.00	19116	10.89							
080A327	ATAB	2010	15	28614	16.05	27872	16.19	27087	16.30	26251	16.40	25366	16.46	24400	16.50	21619	16.30	17624	15.65			

Size 090A327 ATAB

CATALOG NUMBER				CUBIC FEET PER MINUTE AND HORSEPOWER AT STATIC PRESSURE																		
PROP	TYPE	RPM	HP	1/4" SP		1/2" SP		3/4" SP		1" SP		1 1/4" SP		1 1/2" SP		2" SP		2 1/2" SP		3" SP		
				CFM	BHP	CFM	BHP	CFM	BHP	CFM	BHP	CFM	BHP	CFM	BHP	CFM	BHP	CFM	BHP	CFM	BHP	CFM
090A327	ATAB	768	1 1/2	13549	1.65																	
090A327	ATAB	845	2	15422	2.19	11827	2.14															
090A327	ATAB	967	3	18270	3.27	16027	3.29	11432	3.07													
090A327	ATAB	1147	5	22317	5.41	20657	5.49	18510	5.48	14840	5.27											
090A327	ATAB	1313	7 1/2	25957	8.09	24581	8.19	23037	8.24	21006	8.21	17831	7.98									
090A327	ATAB	1445	10	28813	10.75	27601	10.87	26268	10.96	24776	11.00	22714	10.92	19788	10.66							
090A327	ATAB	1654	15	33292	16.07	32266	16.22	31165	16.35	29983	16.44	28697	16.49	27152	16.46	22291	15.94					
090A327	ATAB	1820	20	36823	21.37	35906	21.55	34937	21.70	33906	21.82	32817	21.92	31644	21.97	28459	21.80	23740	21.10			

Size 100A327 ATAB

CATALOG NUMBER				CUBIC FEET PER MINUTE AND HORSEPOWER AT STATIC PRESSURE																		
PROP	TYPE	RPM	HP	1/4" SP		1/2" SP		3/4" SP		1" SP		1 1/4" SP		1 1/2" SP		2" SP		2 1/2" SP		3" SP		
				CFM	BHP	CFM	BHP	CFM	BHP	CFM	BHP	CFM	BHP	CFM	BHP	CFM	BHP	CFM	BHP	CFM	BHP	CFM
100A327	ATAB	643	1 1/2	15089	1.65																	
100A327	ATAB	708	2	17362	2.20																	
100A327	ATAB	810	3	20715	3.28	17207	3.26															
100A327	ATAB	960	5	25429	5.42	23140	5.49	19427	5.39													
100A327	ATAB	1099	7 1/2	29668	8.09	27790	8.20	25593	8.24	21945	8.06											
100A327	ATAB	1210	10	32999	10.77	31353	10.90	29518	10.98	27261	10.97	23586	10.72									
100A327	ATAB	1385	15	38190	16.09	36805	16.26	35300	16.39	33668	16.47	31759	16.48	28891	16.27							
100A327	ATAB	1525	20	42306	21.43	41073	21.63	39757	21.80	38347	21.92	36834	22.00	35091	22.00	29552	21.43					

Size 112A327 ATAB

CATALOG NUMBER				CUBIC FEET PER MINUTE AND HORSEPOWER AT STATIC PRESSURE																		
PROP	TYPE	RPM	HP	1/4" SP		1/2" SP		3/4" SP		1" SP		1 1/4" SP		1 1/2" SP		2" SP		2 1/2" SP		3" SP		
				CFM	BHP	CFM	BHP	CFM	BHP	CFM	BHP	CFM	BHP	CFM	BHP	CFM	BHP	CFM	BHP	CFM	BHP	CFM
112A327	ATAB	672	3	23569	3.29	17819	3.20															
112A327	ATAB	796	5	29138	5.43	25849	5.49	19727	5.25													
112A327	ATAB	912	7 1/2	34158	8.13	31548	8.24	28076	8.22	22134	7.86											
112A327	ATAB	1003	10	38021	10.78	35738	10.92	33110	10.98	28978	10.81	22851	10.22									
112A327	ATAB	1149	15	44132	16.14	42228	16.33	40133	16.46	37765	16.51	34366	16.36	29758	15.95							
112A327	ATAB	1264	20	48894	21.44	47204	21.66	45375	21.83	43401	21.95	41155	21.97	38012	21.80							
112A327	ATAB	1362	25	52927	26.78	51383	27.03	49734	27.23	47967	27.39	46069	27.48	43883	27.48	36933	26.77					
112A327	ATAB	1447	30	56411	32.08	54973	32.35	53451	32.58	51830	32.77	50117	32.90	48257	32.97	43026	32.64	35461	31.47			

Power ratings (BHP) do not include transmission losses.
 Performance certified is for installation type D: Ducted inlet, ducted outlet.
 Performance ratings do not include the effects of appurtenances (accessories).

Performance Data – Belt Driven Model ATAB

Size 125A327 ATAB

CATALOG NUMBER				CUBIC FEET PER MINUTE AND HORSEPOWER AT STATIC PRESSURE																		
PROP	TYPE	RPM	HP	1/4" SP		1/2" SP		3/4" SP		1" SP		1 1/4" SP		1 1/2" SP		2" SP		2 1/2" SP		3" SP		
				CFM	BHP	CFM	BHP	CFM	BHP	CFM	BHP	CFM	BHP	CFM	BHP	CFM	BHP	CFM	BHP	CFM	BHP	CFM
125A327	ATAB	558	3	26580	3.29																	
125A327	ATAB	662	5	33254	5.46	28215	5.47															
125A327	ATAB	758	7 1/2	39143	8.15	35487	8.25	29371	8.07													
125A327	ATAB	834	10	43695	10.82	40536	10.96	36553	10.97	29722	10.59											
125A327	ATAB	955	15	50818	16.17	48199	16.37	45269	16.49	41542	16.45	35574	16.03									
125A327	ATAB	1051	20	56398	21.50	54087	21.74	51552	21.91	48736	22.00	44997	21.88	39455	21.39							
125A327	ATAB	1132	25	61073	26.81	58965	27.09	56684	27.30	54221	27.44	51423	27.48	47514	27.26							
125A327	ATAB	1203	30	65150	32.14	63191	32.44	61096	32.69	58847	32.87	56417	32.98	53561	32.95	44494	32.00					

Power ratings (BHP) do not include transmission losses.
 Performance certified is for installation type D: Ducted inlet, ducted outlet.
 Performance ratings do not include the effects of appurtenances (accessories).

Dimensional Data

Inlet Bell

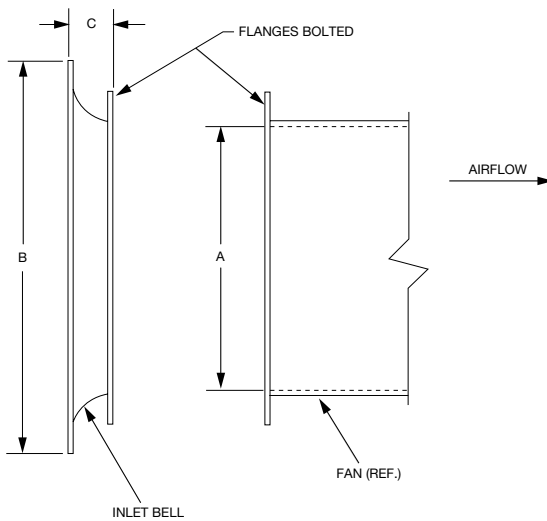

FAN SIZE	A	B	C	WT.
035	13.78	N/A	N/A	N/A
040	15.75	23.75	4.00	10
050	19.68	27.68	4.00	13
063	24.80	32.80	4.00	14
071	27.95	38.00	5.00	19
080	31.50	41.50	5.00	20
090	35.43	45.40	5.00	24
100	39.37	49.40	5.00	28
112	44.09	54.10	5.00	38
125	49.21	63.20	7.00	48

Dimensions are not to be used for construction. AC16554

Inlet & Outlet Cone

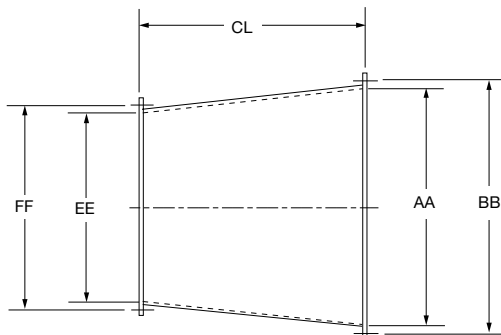

FAN SIZE	AA	BB	CL	EE	FF	GA.	WT.
035	18.0	18.63	8.5	13.78	15.31	18	16
040	20.0	21.13	8.5	15.75	17.38	18	19
050	24.0	25.13	8.5	19.68	21.31	18	22
063	32.0	33.50	13.0	24.80	26.68	18	32
071	36.0	37.50	14.0	27.95	29.85	18	37
080	40.0	41.50	16.0	31.50	33.38	18	45
090	44.0	45.50	18.0	35.43	37.31	18	53
100	50.0	51.50	20.0	39.37	41.25	16	63
112	56.0	57.50	22.0	44.09	46.00	16	75
125	62.0	63.50	25.0	49.21	51.09	14	90

Dimensions are not to be used for construction. AC16562-A

Dimensional Data

Model ATAD, Arrangement 4 – Direct Drive

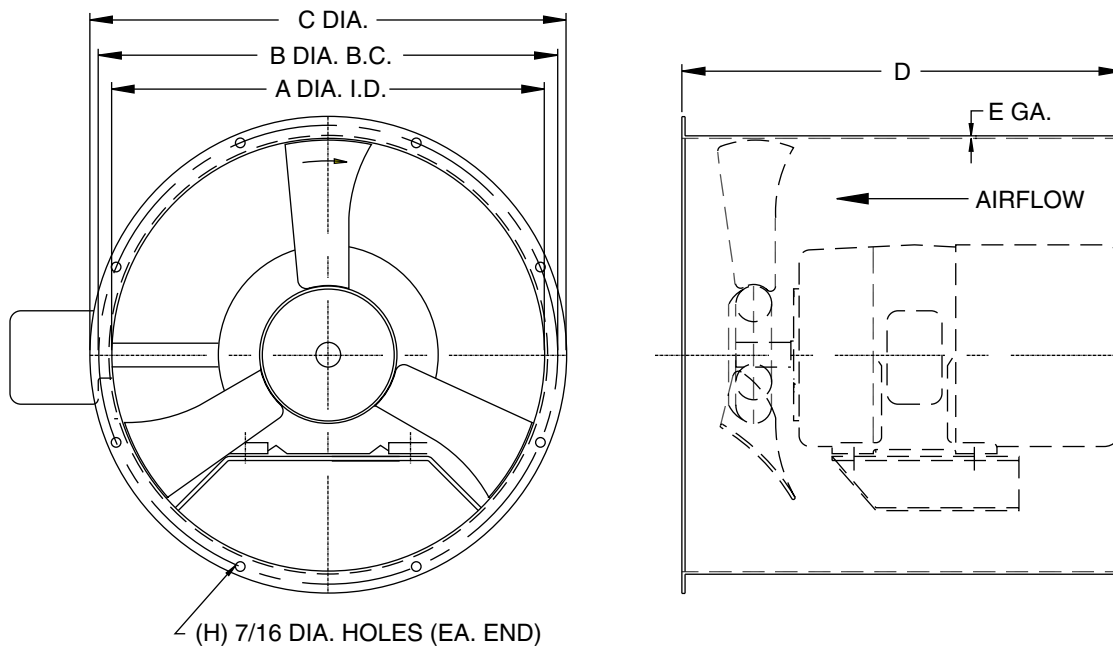

FAN SIZE	A	B	C	D	E (GA.)	H	MAX. MOTOR FRAME	WEIGHT (LBS.)*
035	13 ²⁵ / ₃₂	15 ⁵ / ₁₆	16 ²⁵ / ₃₂	18	14	8	145T/U	25
040	15 ³ / ₄	17 ³ / ₈	18 ³ / ₄	18	12	8	145T/U	37
050	19 ¹ / ₁₆	21 ⁵ / ₁₆	22 ¹ / ₁₆	20	12	8	184T/U	51
063	24 ¹³ / ₁₆	26 ¹ / ₁₆	28 ⁹ / ₁₆	24	10	8	215T/U	104
071	27 ³ / ₃₂	29 ⁷ / ₈	31 ¹⁵ / ₃₂	28	10	12	254T/U	127
080	31 ¹ / ₂	33 ³ / ₈	34 ¹ / ₂	28	7	12	254T/U	191
090	35 ⁷ / ₁₆	37 ⁹ / ₁₆	38 ⁷ / ₁₆	36	7	12	326T/U	275
100	39 ³ / ₈	41 ¹ / ₄	42 ³ / ₈	36	7	12	326T/U	353
112	44 ³ / ₃₂	45 ³ / ₃₂	47 ³ / ₃₂	38	7	16	326T/U	394
125	49 ⁷ / ₃₂	51 ³ / ₃₂	52 ⁷ / ₃₂	40	7	16	365T/U	465

Dimensions are not to be used for construction.

AC16551

*LESS MOTOR

Typical Specifications

Model ATAD, Arrangement 4 – Direct Drive

Fans, where indicated on drawings and schedules, shall be AXIPAL®, Model ATAD, Arrangement 4, direct drive, axial flow type with fan blades being capable of individual manual pitch adjustment while the fan is stopped. Fans shall be as manufactured by Twin City Fan & Blower, Minneapolis, Minnesota, and shall be of the size and capacity as indicated in the fan schedules. Model ATAD fans shall be tested in an AMCA registered laboratory in accordance with AMCA 210 and AMCA 300 test codes and are licensed to bear the AMCA certified ratings seal for both Air and Sound. In addition each unit shall be factory run tested and final trim balanced prior to shipment.

CONSTRUCTION — Fan casings shall be welded of ASTM A-569 low carbon, commercial quality 14-gauge hot rolled steel in sizes through 14" diameter, 12-gauge hot rolled steel in sizes through 20" diameter, 10-gauge hot rolled steel from 24" diameter through 28" diameter, and 7-gauge hot rolled steel on sizes above 30" in diameter. Inlet and outlet flanges shall be integrally rolled mechanically from fan casing sheet steel to insure concentricity and alignment. Accuracy and uniformity of the fan casing shall be insured through the use of welding jigs and fixtures. A fabricated steel motor support base of minimum 3/16" thick plate steel shall be welded into the inlet end of the fan casing.

PROPELLERS — Fan blades shall be permanent mold A319 aluminum precision alloy castings. Fan center hub boss shall be cast iron bolted to stamped steel hub halves coated by electrodeposition. Blade tip clearance shall be within tolerance to meet certified performance. Fan blade pitch angle shall be individually manually adjustable when fan is stopped. The fan propeller shall be secured directly to the motor shaft with knurled cup point set screws in all sizes to 20" diameter and split taper lock bushings in all larger sizes. The motor and propeller assembly shall be enclosed entirely within the fan casing.

BALANCING — The fan propeller assembly shall be statically and dynamically balanced in accordance with ANSI/AMCA 204-96 "Balance Quality and Vibration Levels for Fans" to Fan Application Category BV-3, Balance Quality Grade G6.3. In addition, direct drive fan propellers shall be balanced on the motor shaft after final assembly in the fan casing, in the manufacturing facility to the following peak velocity values, filter-in, at the fan test speed:

Fan Application Category	Rigidly Mounted (In/Sec)	Flexibly Mounted (In/Sec)
BV-3	0.15	0.20

Final test room vibration levels in the axial, vertical, and horizontal planes shall be recorded and a written copy shall be available upon request.

MOTORS — Fan motors shall be manufactured in accordance with current applicable standards of IEEE and NEMA. They shall be foot-mounted, NEMA standard, open drip-proof (ODP), continuous duty, ball bearing with class "B" insulation. External grease fittings with extended grease leads shall be supplied for lubrication of the motor bearings on all motors that provide grease fittings. Motor bearings shall have a minimum L-10 life as defined by AFBMA of at least 40,000 hours (200,000 hours average life).

FINISH — The units, after fabrication, shall be cleaned and chemically pretreated by a phosphatizing process and shall be painted inside and out with two coats of air dry enamel. The fan shall be coated with the following optional finishes:

- | | |
|---|--|
| <input type="checkbox"/> Carbocoat 30 (Replaces Sanitile 550) | <input type="checkbox"/> Hot Dip Galvanizing |
| <input type="checkbox"/> Plasite 4310 – Vinyl Ester | <input type="checkbox"/> Plasite 9500 (Replaces Plasite 1246) |
| <input type="checkbox"/> Plasite 7122L – Air Dry Epoxy Phenolic | <input type="checkbox"/> Plasite 3070 (Replaces Plasite 3066) |
| <input type="checkbox"/> Heresite VR506 – Air Dry Phenolic | <input type="checkbox"/> Dupont ASA – 70 Gray – Polyester (Replaces Farboil) |

GUARANTEE — The manufacturer shall guarantee the workmanship and materials for its AXIPAL®, Model ATAD fans for at least one (1) year from startup or eighteen (18) months from shipment, whichever occurs first.

Dimensional Data

Model ATAB, Arrangement 9 – Belt Driven

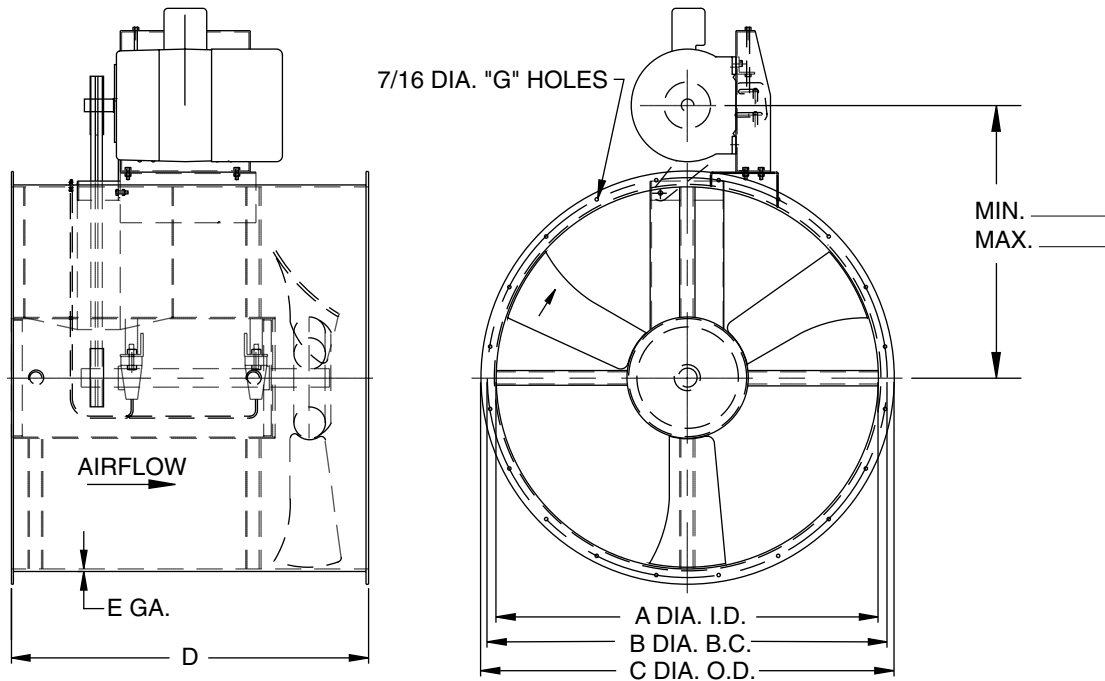

FAN SIZE	A	B	C	D	E (GA.)	G	MAX. MOTOR FRAME	WEIGHT (LBS.)*
040	15 ³ / ₄	17 ³ / ₈	18 ³ / ₄	26	12	8	184T/U	69
050	19 ¹¹ / ₁₆	21 ⁵ / ₁₆	22 ¹¹ / ₁₆	26	12	8	215T/U	82
063	24 ¹³ / ₁₆	26 ¹¹ / ₁₆	28 ⁵ / ₁₆	31	10	8	215T/U	134
071	27 ³¹ / ₃₂	29 ⁷ / ₈	31 ¹⁵ / ₃₂	36	10	12	256T/U	165
080	31 ¹ / ₂	33 ³ / ₈	34 ¹ / ₂	36	7	12	256T/U	277
090	35 ⁷ / ₁₆	37 ⁹ / ₁₆	38 ⁷ / ₁₆	44	7	12	326T/U	373
100	39 ⁹ / ₈	41 ¹ / ₄	42 ³ / ₈	44	7	12	326T/U	418
112	44 ³ / ₃₂	45 ³¹ / ₃₂	47 ⁷ / ₃₂	50	7	16	326T/U	516
125	49 ⁷ / ₃₂	51 ³ / ₃₂	52 ⁷ / ₃₂	52	7	16	365T/U	638

Dimensions are not to be used for construction.

AC16552-A

*LESS MOTOR

Typical Specifications

Model ATAB, Arrangement 9 – Belt Driven

Fans, where indicated on drawings and schedules, shall be AXIPAL®, Model ATAB, Arrangement 9, V-belt driven, axial flow type with fan blades capable of individual manual pitch adjustment while the fan is stopped. Fans shall be as manufactured by Twin City Fan & Blower, Minneapolis, Minnesota, and shall be of the size and capacity as indicated in the fan schedules. Model ATAB fans have been tested in an AMCA registered laboratory in accordance with AMCA 210 and AMCA 300 test codes and are licensed to bear the AMCA certified ratings seal for both Air and Sound. In addition each unit shall be factory run tested and final trim balanced prior to shipment.

CONSTRUCTION — Fan casings shall be welded of ASTM A-569 low carbon, commercial quality 12-gauge hot rolled steel in sizes through 20" diameter, 10-gauge hot rolled steel from 24" diameter through 28" diameter, and 7-gauge hot rolled steel on sizes greater than 30" in diameter. Inlet and outlet flanges shall be integrally rolled mechanically from fan casing sheet steel to insure concentricity and alignment. Accuracy and uniformity of the fan casing shall be insured through the use of welding jigs and fixtures. The motor base plate shall be fabricated of minimum 3/16" steel plate and welded to the exterior of the fan casing. The adjustment of belt tension shall be accomplished with an adjustable slide rail base.

PROPELLERS — Fan blades shall be permanent mold A319 aluminum alloy precision castings. Fan center hub boss shall be cast iron bolted to stamped steel hub halves coated by electrodeposition. Blade tip clearance shall be within tolerance to meet certified performance. Fan blade pitch angle shall be individually manually adjustable when fan is stopped. The fan propeller shall be secured to the fan shaft with knurled cup point set screws in all sizes to 20" diameter and split taper lock bushings in all larger sizes.

SHAFT & BEARINGS — All fans shall be supplied with a shaft of AISI 1045 steel material that has been properly turned, ground, and polished for accuracy. The shaft shall be supported by a matched pair of sealed pillow block bearings. Grease leads are to be extended from the fan shaft bearings to zerk fittings mounted on the exterior of the fan casing to facilitate bearing relubrication without the need to gain service access inside the ductwork or the fan casing. All fan bearings are to have an L-10 minimum life as defined by AFBMA of at least 20,000 hours. This L-10 minimum life converts to an average bearing life in excess of 100,000 hours.

DRIVES — Fan drives shall include cast iron sheaves and non-static conducting belts. Fans equipped with motors up to and including five horsepower will be furnished with a variable pitch type drive sheave to allow for minor speed adjustment of the fan propeller during system balance. Fans equipped with larger motors will be furnished with a fixed drive sheave. A belt guard or an optional motor cover is to be provided with all belt driven fans to afford personnel safety and general traffic protection.

MOTORS — Fan motors shall be manufactured in accordance with current applicable standards of IEEE and NEMA. They shall be foot-mounted, NEMA standard, open drip-proof (ODP), continuous duty, ball bearing with class "B" insulation.

BALANCING — The propeller assembly shall be statically and dynamically balanced in accordance with ANSI/AMCA 204-96 "Balance Quality and Vibration Levels for Fans" to Fan Application Category BV-3, Balance Quality Grade G6.3. In addition, belt driven fan propellers shall be balanced on the fan shaft after final assembly in the fan casing, in the manufacturing facility to the following peak velocity values, filter-in, at the fan test speed:

Fan Application Category	Rigidly Mounted (In/Sec)	Flexibly Mounted (In/Sec)
BV-3	0.15	0.20

Final test room vibration levels in the axial, vertical, and horizontal planes shall be recorded and a written copy shall be available upon request.

FINISH — The units, after fabrication, shall be cleaned and chemically pretreated by a phosphatizing process and shall be painted inside and out with two coats of air dry enamel. The fan shall be coated with the following optional finishes:

- | | |
|---|--|
| <input type="checkbox"/> Carbocoat 30 (Replaces Sanitile 550) | <input type="checkbox"/> Hot Dip Galvanizing |
| <input type="checkbox"/> Plasite 4310 – Vinyl Ester | <input type="checkbox"/> Plasite 9500 (Replaces Plasite 1246) |
| <input type="checkbox"/> Plasite 7122L – Air Dry Epoxy Phenolic | <input type="checkbox"/> Plasite 3070 (Replaces Plasite 3066) |
| <input type="checkbox"/> Heresite VR506 – Air Dry Phenolic | <input type="checkbox"/> Dupont ASA – 70 Gray – Polyester (Replaces Farboil) |

GUARANTEE — The manufacturer shall guarantee the workmanship and materials for its AXIPAL®, Model ATAB fans for at least one (1) year from startup or eighteen (18) months from shipment, whichever occurs first.

Unlimited Options...

Commercial Fans

Centrifugal Fans • Utility Sets • Inline Centrifugal Fans • Plenum Fans
Radial Bladed Fans • Centrifugal Roof & Wall Exhausters • Filtered Supply Fans
Gravity Relief Ventilators • Ceiling & Cabinet Ventilators • Propeller Wall Fans
Tubeaxial Fans • Vaneaxial Fans • Propeller Roof Ventilators
Fume Hood/Smoke & Heat Exhaust Fans • Mancoolers • Fiberglass Fans

Industrial Fans

Centrifugal Fans • Forward Curved & Air Kit Components • Inline Centrifugal Fans
Plug Fans • Radial Bladed Fans • Radial Tip & High Efficiency Fans
Pressure Blowers • Tubeaxial Fans • Vaneaxial Fans

Custom Design Fans

Easy Access Fans • Insulated Fans • Inlet Boxes - Integral and Detached
Inlet Box Dampers • Independent Bearing Pedestals • Split Housings • Bolted Housings
Spark Resistant Construction • Ultra Fine Balancing • Modified Widths and Diameters
Variable Frequency Drives • API Specifications • Special Materials • Anti-Rotation Devices
Sleeve Oil Bearings • Volume Control Dampers • Inlet Vane Control with External Mechanisms

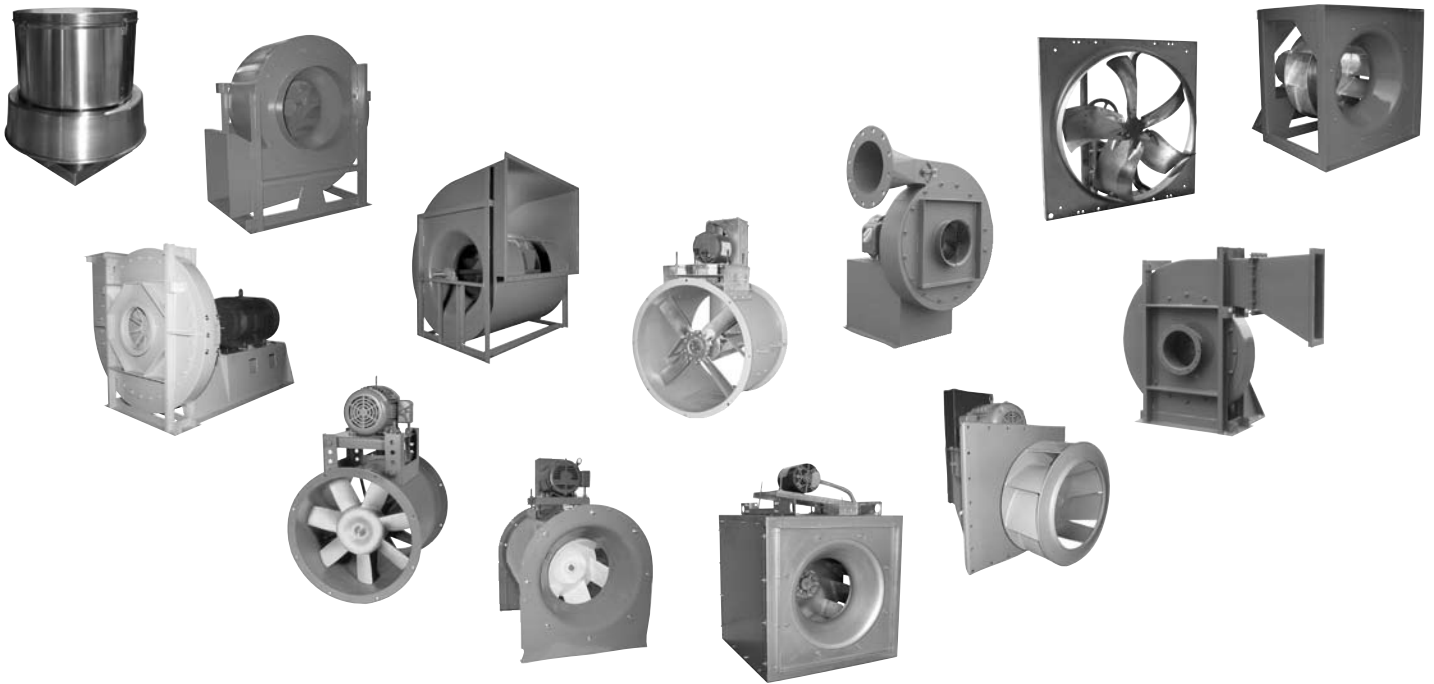

...One Solution.



5959 TRENTON LANE NORTH • MINNEAPOLIS, MN 55442-3237

PHONE: 763-551-7600 • FAX: 763-551-7601

WWW.TCF.COM